

LXC9220/LXC9210

Generator Controller User Manual.

Ver1.2 Date: 2013/07/01

LXC9220 Series



LXC9210 Series



Software Version

Date	Versio	Note
2012-08-21	1.1	Increased DTU binding and remote monitoring function
2013-07-01	1.2	Increase the panel can set parameters of the items

Contents

1. Technical parameter.....	4
2. Summary.....	5
3. Performance and characteristics.....	5
4. Modules comparison.....	8
4.1. Modules comparison.....	8
4.2. Models abbreviation.....	8
5. Operation.....	9
5.1. Indicator light.....	9
5.2. Key functions.....	10
5.3. LCD display.....	11
5.4. Basic configuration.....	14
5.5. Advanced configuration.....	14
6. Auto start/stop operation.....	15
6.1. Starting sequence:.....	15
6.2. Stopping sequence:.....	15
6.3. Manual start/stop operation.....	16
6.4. Manual start operation.....	16
6.5. Manual stop operation.....	16
6.6. LXC9220 switch control procedures.....	16
6.6.1. Manual transfer procedures:	16
6.6.2. Auto transfer procedures:.....	17
6.7. LXC9210 switch control procedures.....	17
6.7.1. Manual transfer procedures:.....	17
6.7.2. Auto control procedures:.....	17
7. SMS remote control、 wireless remote control.....	18
7.1. LXI680 Connection diagram.....	19
7.2. GSM Alarm setting.....	20
7.3. Based on the GPRS DTU remote online monitoring.....	20

7.4. Wireless connection schematic diagram.....	21
7.5. Connect the controller through the DTU remote.....	22
7.6. DTU with the binding of the controller.....	22
8. History query.....	23
8.1.1. Event log.....	23
8.1.2. Historical alarm data query.....	23
9. Protection.....	24
9.1. Shutdown alarm.....	24
9.2. Trip and stop alarm.....	25
9.3. Trip alarm.....	26
9.4. Warnings.....	26
10. Wirings.....	28
11. Parameters setting.....	30
11.1. Basic configuration parameters.....	30
11.2. Basic configuration.....	31
11.3. Advanced configuration parameter.....	33
11.4. Defined contents of configurable input ports.....	33
11.5. Enable definition of programmable output ports.....	35
11.6. Defined period output.....	37
11.7. Sensor selection list.....	39
11.8. Pressure unit conversion table.....	39
11.9. Conditions of crank disconnect selection.....	40
12. Typical application.....	40
13. Installation.....	44
14. Common faults and exclusion.....	45
15. Product packaging.....	45

1. Technical parameter

Items	Contents
Operating Voltage	DC8.0V to DC35.0V, Continuous Power Supply.
Power Consumption	<4W (standby ≤2W)
Alternator Input Range 3-Phase 4-Wire 3-Phase 3-Wire Single-Phase 2-Wire 2-Phase 3-Wire	12V - 360 V AC (ph-N) 20V - 620 V AC (ph-ph) 12V - 360 V AC (ph-N) 12V - 360 V AC (ph-N)
Alternator Frequency	50/60Hz
Speed sensor voltage Vpp	2.2 - 100Vpp (Peak to peak)
Speed sensor Frequency	10,000 Hz (max.)
Start Relay Output	16Amp Controller Power Voltage Output
Fuel Relay Output	16Amp Controller Power Voltage Output
Programmable Relay Output 1	7Amp Controller Power Voltage Output
Programmable Relay Output 2	7Amp Controller Power Voltage Output
Programmable Relay Output 3	7Amp Controller Power Voltage Output
Programmable Relay Output 4	7Amp 250VAC voltage free output
Programmable Relay Output 5	7Amp 250VAC voltage free output (LXC9220)
Programmable Relay Output 6	7Amp 250VAC voltage free output (LXC9220)
Case Dimension	254mm x 180 mm x 44 mm
Panel Cutout	218mm x 160mm
C.T. Secondary	5A rated
Working Conditions	Temperature: (-25~+70)°C Humidity: (20~90)%
Storage Condition	Temperature: (-40~+85)°C
Protection Level	IP55: when waterproof rubber seal installed between controller and panel fascia. IP42: when waterproof rubber seal is not installed between the controller and panel fascia.
Insulating Intensity	Object: input/output/power Quote standard: IEC688-1992 Test way: AC1.5kV/1min leakage current: 3mA
Net Weight	0.86kg

2. Summary

LXC92X0 Series of power plant automation controller for the automation and monitoring system of a single diesel generator sets, use 32-bit microprocessor technology, achieve generator sets automatic boot/shutdown, the precision measurement of various parameters, alarm protection and three remote function. The controller uses a large-screen LCD (240*128LCD)graphics display, all the important parameters can be displayed in page, save the page. At the same time can be displayed Chinese, English and other languages, all parameters can be adjusted from the controller panel, can also be a PC through a USB interface tweaks and RS485 or GPRS remote adjustment and monitoring. Its structure is compact, simple wiring, high reliability, automation control systems are widely used in all types of generator sets and fire pumps.

3. Performance and characteristics

LXC9210: Auto Start Module. It controls gen-set to start or stop automatically by remote start signal.

LXC9220: Auto Main Failure, updates based on LXC9210, especially for automatic system composed by gens and mains.

Main characteristics.

- ❖ With ARM-based 32-bit MCU, highly integrated hardware, new reliability level;
- ❖ 240x128 LCD with backlight, multilingual interface(including English, Chinese or other languages) which can be chosen at the site, making commissioning convenient for factory personnel;
- ❖ All parameters can use the computer via USB, RS232, RS485 interface to connect and adjust, while the internal FLASH memory within the controller in the system when power is not lost;
- ❖ 99% of the parameters can be set directly from the front panel for easy on-site commissioning;
- ❖ RS485 communication port enabling remote control, remote measuring, remote communication via ModBus protocol (controller with RS485 port only);
- ❖ Equipped with SMS(Short Message Service)function. When genset is alarming, controller can send short messages via SMS automatically to max.5 telephone numbers. besides, generator status can be controlled and checked using SMS. With advanced networking capabilities, via GPRS mobile network and Internet connectivity, in any place where the network can be remotely monitor;(Need to install the GPRS module: LXI680);
- ❖ Equipped with CANBUS port and can communicate with J1939 genset. Not only can users monitoring frequently-used data (such as water temperature, oil pressure, speed, fuel consumption and so on) of ECU machine, but also control starting up, shutdown , raising speed and speed droop via CANBUS port. (controller with CAN BUS port only);
- ❖ Suitable for 3-phase 4-wire, 3-phase 3-wire, single phase 2-wire, and 2-phase 3-wire systems with voltage 120/240V and frequency 50/60Hz;
- ❖ Collects and shows 3-phase voltage, current, power parameter and frequency of generator or mains;
- ❖ For Mains, controller has over and under voltage, over and under frequency, loss of phase and phase sequence wrong detection functions; For generator, controller has over and under voltage, over and under frequency, loss of phase, phase sequence wrong, over and reverse power, over current functions;
- ❖ 3 fixed analog sensors(temperature, oil pressure and liquid level),more kinds of curves of temperature,oil pressure, fuel level can be used directly and users can define the sensor curves by themselves;
- ❖ 2 configurable sensors can be set as sensor of temperature, pressure or fuel level;
- ❖ Protection: Automatic start/stop of the genset, ATS(Auto Transfer Switch)control with perfect fault indication and protection function. When multiple warnings occur, the warning bar will rotate to display them, so that we can analyze the reasons;

- ❖ All output ports are relay-out, And the main output 16A relay outputs and three passive relay output, more user-friendly;
- ❖ Parameter setting: parameters can be modified and stored in internal FLASH memory and cannot be lost even in case of power outage; most of them can be adjusted using front panel of the controller and all of them can be modified using PC via USB or RS485 ports;
- ❖ With advanced networking capabilities, via GPRS mobile network and Internet connectivity, in any place where the network can be remotely monitor;
- ❖ A variety of starting conditions for success (speed sensor, oil pressure, power generation) to select, to facilitate the needs of special occasions;
- ❖ Wide power supply range (8 ~ 35) VDC, can adapt to different environment starting battery voltage, can under the low voltage of starting motor moment continue to work for 3 seconds;
- ❖ Fault history with 200, and can record the fault instant oil pressure ,water temperature, voltage, current and other important parameters;
- ❖ Equipped with real-time clock, scheduled start & stop generator(can be seas start gen-set once a day/week/month with load or not),reach automatic maintenance;
- ❖ Can be used on pumping units and as an indicating instrument (indicate and alarm are enable only, relay is inhibited);
- ❖ 3 set of maintenance functions, can be set for the machine maintenance cycle .Maintenance time to action can be set up(only warning or alarm stop);
- ❖ Waterproof security level IP55 due to rubber seal installed between the controller enclosure and panel fascia;
- ❖ Improved LCD wear-resistance and scratch resistance due to hard screen acrylic;
- ❖ Silicon panel and push buttons for better operation in high-temperature environment,and has a good waterproof performance;
- ❖ Modular design, anti-flaming ABS plastic enclosure, plug gable connection terminals and embedded installation way, compact structure with easy mounting.

Special industry application characteristics:

- ❖ Leasing industry applications: management provides the perfect solution: leased out via PC remote Management of the unit, you can monitor all operating parameters (oil pressure, water temperature, voltage, current, power, etc),you can always change the configuration to protect the unit is not proper application, can record 200 detailed fault information, including: time to failure, because ,when the voltage, current, power, oil pressure, water temperature and other key parameters, and ready to upload to the monitoring machine. Another multi-level password management options to facilitate the lease management;
- ❖ Fire pump industry applications: Close electrical parameter measurement function, use powerful Programmable input and output ports and internal programmable logic to achieve automated pump control system. Instead of the conventional engine controller PLC + simple manner ,making the system more stable and reliable;
- ❖ Air compressor industry applications: Close voltage measurements protection, according to the need to configure programmable analog input, overload protection , with programmable digital inputs, complete startup control, temperature and pressure control, protection parameter settings.

Fully functional, and can detect almost all the generating units of electrical parameters and non-electrical parameters.

Mains

Line voltage Uab, Ubc, Uca
Phase voltage Ua, Ub, Uc
Frequency Hz

Gens

Line voltage Uab, Ubc, Uca
Phase voltage Ua, Ub, Uc
Frequency Hz
Load current IA, IB, IC
Each phase and total active power kW
Each phase and total reactive power kVar
Each phase and total apparent power kVA
Each phase and average power factor PF
Accumulate total gens power kWh、kVarh、kVAh

Sensor

Temperature WT °C/°F Choose to display
Oil pressure OP kPa/Psi/Bar Choose to display
Fuel level (FL) %(unit)
Speed (SPD) RPM (unit)
Voltage of Battery(VB) V(unit)
Voltage of Charger(VD) V(unit)
Hour count(HC) can accumulate Max.65535hours
Start times can accumulate Max.65535times

Mains and generator abnormal conditions:

Voltage is too high
Voltage is too low
Frequency is too high
Frequency is too low
Phase loss
Reverse phase
Loss of power

The fault display and protection function project:

High water temperature warn
High water temperature shutdown alarm
Low oil pressure warning
Over speed shutdown alarm
Box high temperature warn
Low fuel level warn
Battery voltage is too high warn
Battery voltage is too low warn
Load over current shutdown alarm
Failed to stop alarm
Emergency stop alarm
Oil pressure sensor open circuit shutdown alarm

4. Modules comparison

4.1. Modules comparison

Items		LXC 9210	LXC 9220	LXC 9310	LXC 9320	LXC 9410	LXC 9420	LXC 9610	LXC 9620	LXC 9510	LXC 9520
LCD	Dimension	4.3"									
	pixel	240×128									
AMF			•		•		•		•		•
BUS Monitoring										•	
Parallel Connection										•	•
Extension Module								•	•		
Input Port Number		8	8	8	8	8	8	8	8	8	8
Output port Number		8	8	8	8	8	8	8	8	8	8
Sensor Number		5	5	5	5	5	5	5	5	5	5
Neutral Current								•	•		
Schedule Function		•	•	•	•	•	•	•	•	•	•
ETHERNET								•	•		
RS485				•	•	•	•	•	•	•	•
GSM		•	•	•	•	•	•	•	•	•	•
J1939						•	•	•	•	•	•
USB		•	•	•	•	•	•	•	•	•	•
Real-time clock		•	•	•	•	•	•	•	•	•	•
Event log		•	•	•	•	•	•	•	•	•	•
SD Card								•	•		

4.2. Models abbreviation

Abbreviation	Description
LXC9X20	All LXC9X20 series AMF controllers
LXC9X10	All LXC9X10 series ASM(Auto Start Module) controllers

✧ **NOTE:**















- ① Two of the outputs are fixed: start output and fuel output.
- ② LXC9X20 /LXC9X10 analog sensors are composed by 3 fixed sensors (temperature, pressure, liquid level) and 2 configurable sensors.







5. Operation

5.1. Indicator light



5.2. Key functions

	Stop	Stop running generator in Auto/Manual mode; Reset alarm in stop mode; During stopping process, press this button again to stop generator immediately. Lamp test (press at least 3 seconds);
	Start	Start genset in Manual mode or Test mode.
	Manual Mode	Press this key and controller enters in Manual mode.
	Auto Mode	Press this key and controller enters in Auto mode
	Running With Load	Press this key and controller enters in Manual Testing mode. (LXC9210 without)
	Mute/ Alarm Reset	1. Alarming sound off; 2. If there is trip alarm, pressing the button can reset this alarm. But you can't reset other alarm types
	Gen Close/Open	Can control generator to switch on or off in manual mode.
	Mains Close/Open	Can control mains to switch on or off in manual mode (LXC9210 without)
	Set/Confirm	1. Set parameters, press Kin can set the parameters. 2. Set parameters, press the Kin can set parameters to confirm. 3. Long press this button, can enter the basic parameter Settings. 4. Press the confirm key and stop key at the same time, can enter the parameter Settings.
	Up/Increase	Up cursor and increase value in setting menu.
	Down/Decrease	Down cursor and decrease value in setting menu.
	Left	1. Screen scroll; 2. Left move cursor in setting menu.
	Right	1. Screen scroll; 2. Right move cursor in setting menu.
	Exit	1. When the screen displays other parameters, press this key to return to the main screen. 2. Set the parameters, press this key can cancel parameter settings. 3. Enter the parameter setting, long press this button to return to the main screen.

- ✧ **Tips:** In the main interface, press   and from view different interface, press  to return to the main interface.
- ✧ **Tips:** Press  over 3 seconds, go into basic parameters setting menu.
- ✧ **Tips:** Press  and  simultaneously, enter into advanced parameters setting menu if password is correct.
- ✧ **Tips:** default password is 0000, user can change it in event of others change the senior parameters setting. Please closely remember it after changing. If you forget your password, please contact our

customer service, at the same time press  and  all the information back to the service personnel. (Example, under the figure information)

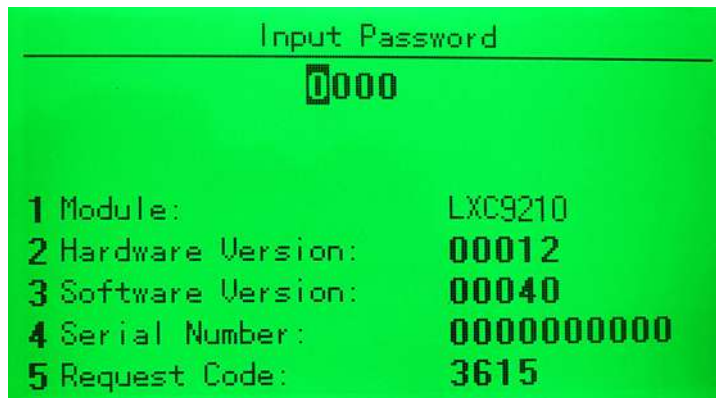

5.3. LCD display

In the main interface, press  and  from the different interfaces, press  to return to the initial page.

- **Main Interface (Commonly used parameter interface)**

(The main interface contains, engine, generator, and status display)

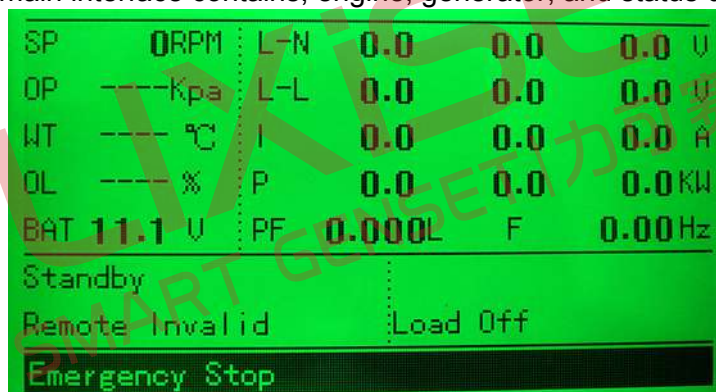

- **Engine parameters**

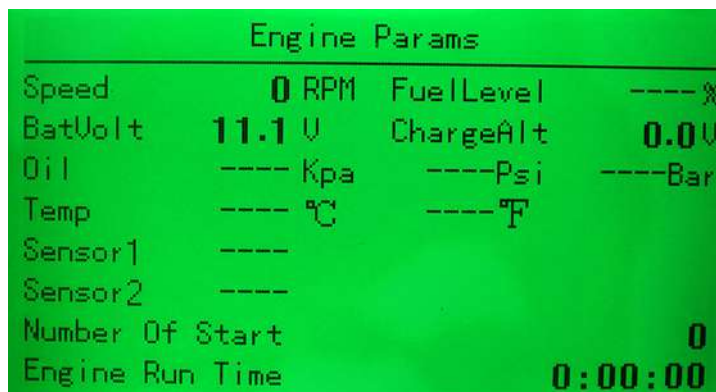

● **Load**

Load State				
	L1	L2	L3	Total
I	0.0	0.0	0.0	0.0 A
P	0.0	0.0	0.0	0.0 KW
Q	0.0	0.0	0.0	0.0 Kvar
S	0.0	0.0	0.0	0.0 KVA
PF	0.000L	0.000L	0.000L	0.000L
Gen KW hours				0.0Kwh
Gen KVAh hours				0.0Kvarh

● **Generator**

Generator Freq				0.00Hz
	L1(L1-2)	L2(L2-3)	L3(L3-1)	
L-N	0.0	0.0	0.0	U
L-L	0.0	0.0	0.0	U
Phase	0.0	0.0	0.0	

Relay Output Status					
OUT1	OUT2	OUT3	OUT4	OUT5	OUT6
↘	↘	↘	↘	↘	↘

● **Mains Interface (LXC9210 No such interface)**

Mains Freq				0.00Hz
	L1(L1-2)	L2(L2-3)	L3(L3-1)	
L-N	0.0	0.0	0.0	U
L-L	0.0	0.0	0.0	U
Phase	0.0	0.0	0.0	

Digital Input Status							
IN1	IN2	IN3	IN4	IN5	IN6	IN7	IN8
↘	↘	↘	↘	↘	↘	↘	↘

● **Warning Record**

Warning Record					
1/ 27 1970-03-09 02:09:20 Monday					
SP	0RPM	L-N	0.0	0.0	0.0 U
OP	0Kpa	L-L	0.0	0.0	0.0 U
WT	0 °C	I	0.0	0.0	0.0 A
OL	0 %	P	0.0	0.0	0.0 KW
BAT	10.8 U	PF	0.000L	F	0.00Hz
Emergency Stop					

- **Basic configuration parameters**

Base Configs	
1 Language:	ENGLISH
5 Fast Loading Feature:	Disable
6 Crank Success Items:	6.Oil+Speed+Freq
7 Flywheel Teeth(10-300):	060
8 Rated Speed(0-6000RPM):	1500
9 Gen Rated Volt(30-30000V):	00220
10 Gen Rated Freq(10-65Hz):	50.0
11 Curr Transform(6000/5A):	0500









- **Input Password (Password input interface into the Advanced Configuration)**

Input Password	
0000	
1 Module:	LXC9210
2 Hardware Version:	00012
3 Software Version:	00040
4 Serial Number:	0000000000
5 Request Code:	3615

- **Advanced configuration parameters**

Advance Configs	
1 Application	Settings
2 Timer	Settings
3 Engine	Settings
4 Generator	Settings
5 Load	Settings
6 Analog Sensor	Settings
7 Digital Input	Settings
8 Relay Output	Settings



5.4. Basic configuration

The basic configuration parameters interface has the following options, press   to select up and down the items you need to change, press  to enter the selected item to modify the state, press   can modify the value,   Can shift, Change after press  to save the changes.

✧ **Tips:** This series of controllers using a large-screen display, just a basic configuration menu to query and modify all items.

- | | |
|------------------------------------|---|
| 1 Language Selection: | 17 Start delay(0-3600s): |
| 2 Mains detection option: | 18 Stop delay(0-3600s): |
| 3 Mains rated voltage(30-30000V): | 19 Return delay(0-3600s): |
| 4 Mains rated frequency (10-65Hz): | 20 Preheat timer(0-3600s): |
| 5 Fast load: | 21 Cranking timer(3-60s): |
| 6 Starting conditions for success: | 22 Crank Rest Timer (3-60s): |
| 7 Engine Teeth(10-300): | 23 Safety on time(0-3600s): |
| 8 Engine rated speed(0-6000RPM): | 24 Start idle timer(0-3600s): |
| 9 Gen rated voltage(30-30000V): | 25 Warming up timer(0-3600s): |
| 10 Gen rated frequency(10-65Hz): | 26 Cooling timer (0-3600s): |
| 11 CT ratio(6000/5A): | 27 Stop idle timer(0-3600s): |
| 12 Rated current(5-6000A): | 28 ETS(Energize to Stop) hold delay(0-3600s): |
| 13 Rated power(KW): | 29 Wait stop delay(0-3600s): |
| 14 Battery Voltage (0-600V): | 30 After stop delay (0-3600s): |
| 15 Module date: | 31 Controller information: |
| 16 Module time: | |

5.5. Advanced configuration

Press the   key, enter the correct password to enter the advanced parameters configuration menu, press  to return to the previous menu.

- | | |
|-----------------------------|---------------------------|
| 1 Application configuration | 9 ATS |
| 2 Timer | 10 Mains |
| 3 Engine | 11 Module |
| 4 Generator | 12 Scheduled |
| 5 Load | 13 Maintenance |
| 6 Analog Sensor | 14 GSM(SMS) |
| 7 Digital Inputs | 15 Controller information |
| 8 Digital Outputs | 16 Calibration parameters |

6. Auto start/stop operation

Press  , its indicator lights, and controller enters Auto mode.





6.1. Starting sequence:

- ❖ LXC9220: When Mains is abnormal (over and under voltage, over and under frequency, loss of phase, phase sequence wrong), it enters into “mains abnormal delay” and LCD display count down time. When mains abnormal delay is over, it enters into “start delay”; it also enters into this mode when “remote start on load” is active.
- ❖ LXC9210: Generator enters into “start delay” as soon as “Remote Start on Load” is active.
- ❖ Start Delay timer is shown at the bottom line of LCD.
- ❖ When start delay is over, preheat relay outputs (if this be configured), “preheat start delay XX s” is shown at the bottom line of LCD.
- ❖ When preheat delay is over, fuel relay outputs 1s and then start relay output; if engine crank fails during “cranking time”, the fuel relay and start relay deactivated and enter into “crank rest time” and wait for next crank.
- ❖ If generator crank fails within setting times, controller will send “Fail to start” and the warning will be shown on LCD at the same time.
- ❖ In case of successful crank attempt, “safety on timer” starts. During this period, low oil pressure, high water temperature, under speed, charge failure alarms are disabled. As soon as this delay is over, “start idle delay” is initiated (if configured).
- ❖ During “start idle delay”, under speed, under frequency, under voltage alarms are inhibited. When this delay is over, “warming up delay” starts (if configured).
- ❖ When “warming up delay” is over, if generator state is normal, its indicator will be illuminated. If voltage and frequency has reached on-load requirements, the closing relay will be energized, generator will accept load, generator power indicator will turn on, and generator will enter Normal Running state; if voltage and frequency are abnormal, the controller will initiate alarm (alarm type will be displayed on LCD alarm page).



6.2. Stopping sequence:

- ❖ LXC9220: when mains return normal during gen-set running, enters into “mains voltage Normal delay”. When mains normal delay are over, enter into “stop delay” and mains indicator lights; also can be into this mode when “remote start on load” is inactive.
- ❖ LXC9210: generator enters into “stop delay” as soon as “Remote Start” is inactive.
- ❖ When stop delay is over, close generator relay is un-energized; generator enters into “cooling time relay”. After “transfer rest time”, close mains relay is energized. Generator indicator extinguishes while mains indicator lights.
- ❖ Idle relay is energized as soon as entering “stop idle delay”.
- ❖ If enter “ETS hold delay”, ETS relay is energized. Fuel relay is deactivated and decides whether generator is stopped or not automatically.
- ❖ Then enter “gen-set Completely stop time”, auto decides whether generator is stopped or not automatically.
- ❖ When the unit is completely stopped, enter the power generation standby mode; if can't stop the alarm controller. (LCD screen displays downtime failure warning)

6.3. Manual start/stop operation

LXC9220/LXC9210: Press , controller enters into Manual starts mode and its indicator lights. Press , then controller enters into "Manual Test Mode" and its indicator lights. In the both mode, press  to start generator, can automatically detect crank disconnected, and generator accelerates to high-speed running. With high temperature, low oil pressure and abnormal voltage during generator running, controller can protect genset to stop quickly (please refer to No.4~9 of Auto start operation for detail procedures). In "manual mode ", Generator load based on judging the mains is normal, mains is normal, not conversion, load switch mains is unusual, load switch in the power generation side. In "Manual Test Mode ", generator runs well, whether mains normal or not, loading switch must be transferred to generator side.

6.4. Manual start operation

LXC9220/LXC9210: Press , controller enters into Manual mode and its indicator lights. Press  to start generator, can automatically detect crank disconnected, and generator accelerates to high-speed running automatically. With high temperature, low oil pressure and abnormal voltage during generator running, controller can protect genset to stop quickly (please refer to No.4~9 of Auto start operation for detail procedures). After generator runs well, if remote start signal is active, controller will send closing gens signal; if the remote signal is inactive, controller won't send closing signal.

6.5. Manual stop operation

Press  can stop the running generators. (please refer to No.3~7 of Auto stop operation for detail procedures).

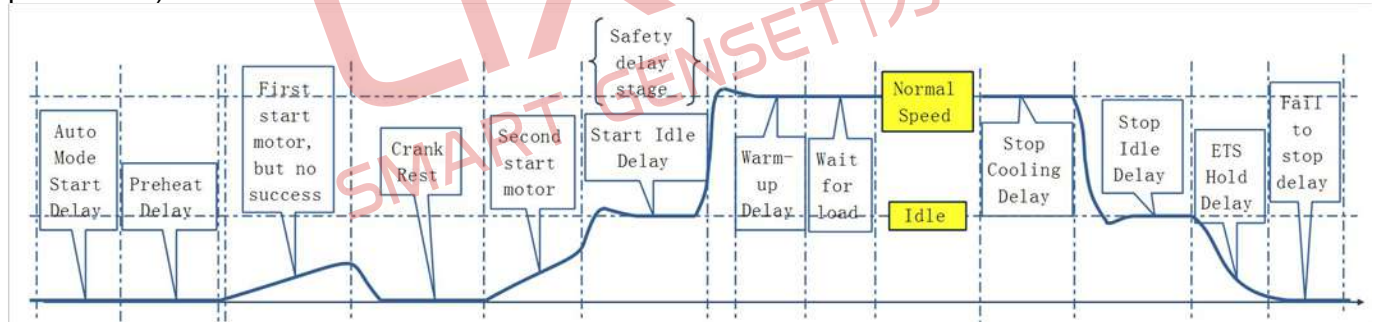

6.6. LXC9220 switch control procedures

6.6.1. Manual transfer procedures:

When controller is in Manual mode, the switch control procedures will start through manual transfer. But according to the ATS Switch configuration is different, the specific process have some distinction.

❖ **If "Open breaker detect" is "SELECTD is able"**

After the press power close break-brake key, according to the current load case in 2 processes:

- 1、 generator is opened when the generator is load; If the load is closed, the generator is open;
- 2、 Mains is opened when the mains is load; When the end of the sub-gate delay generator closing; Press mains close or open key, if mains have taken load, will output unload open; If the load is opened, the mains close; If the generator is load, the generator to open, when the end of the open delay, then mains to close.

❖ **If "Open breaker detect" is "SELECT Enable" and "Closing auxiliary input"**

Principles as above, but in every time after closing and break-brake auxiliary input switching state through testing to determine. If not normal will be closing or opening failure warnings. **Note: This warning can be Resolved by the alarm mute.**

6.6.2. Auto transfer procedures:

When controller is in Manual Test, Auto or Stop mode, switch control procedures will start through Automatic transfer.

❖ **If "Open breaker detect" is " SELECT Disable " and "Closing auxiliary input"**

1、Mains load is transferred into generator load, after the delay of switch off and transfer interval, generator switch on. Detecting transfer fail while generator switch on. After detecting time up, if switch on fail, then wait for generator switch on. If transfer fail and warning " SEL Enable", there is alarming signal.

Note: This warning can be Resolved by the alarm mute.

2、Gens to a the mains load, the same principle.

❖ **If" Open breaker detect" is "SELECT Disable"**

1、Mains load is transferred into generator load, after the delay of switch off and transfer interval, generator switch on. Detecting transfer fail while generator switch on. After detecting time up, if switch on fail, then wait for generator switch on. If transfer fail and warning " SEL Enable", there is alarming signal.

2、Gens to a the mains load, the same principle.

❖ **If input port not configured as Close Mains Auxiliary**

Mains load be transferred into gens load, after switch off and transfer interval delay, gens switch on. The way to transfer gens load to mains load is as same as above.

6.7. LXC9210 switch control procedures

6.7.1. Manual transfer procedures:

When controller is in Manual mode, manual transfer will be executive. Users can control switch on or off by pressing key. Press generator switch on or off key, if generator have taken load, will output unload signal; if taken no load, generator will output load signal.

6.7.2. Auto control procedures:

When controller is in manual test, auto or stop mode, switch control procedures will start auto transfer.

❖ **If input port is configured as Close Mains Auxiliary**

1、If "Open breaker detect" is "SELECT Disable"

Gens load is transferred into generator un-load, after the delay of switch off, detecting transfer failure while switch off output. When detecting time up, if switch off failed, to wait for switch off. Otherwise, switch off is completed. Gens unload is transferred into gens load, after the delay of switch on, detecting transfer failure while switch on outputting. When detecting time up, if switch on failed, to wait for switch on. Otherwise, switch on is completed. If transfer failed and warning "SEL Enable", there is alarming signal whatever switch on or off failure.

2、If "Open breaker detect" is "SELECT Enable"

Gens load is transferred into gens unload, after the delay of switch off, switch off is completed. Gens unload is transferred into gens load, after the delay of switch on, detecting transfer failure while switch on outputting. When detecting time up, if switch on failed, to wait for switch on. Otherwise, switch on is completed. If transfer failure warning is "SEL Enable", there is warning signal that "switch on fail".

❖ **If input port is not configured as Close Mains Auxiliary**

Gens un-load is transferred into gens load, gens switch on and output.

Gens load is transferred into gens un-load, gens switch off and output.

NOTE:When using ATS of no interposition, switch off detecting is “SELECT Disable”; When using ATS of having interposition, switch off “SELECT Disable” or “SELECT Enable” both are OK. If choose “SELECT Enable”, switch off output should be configured; When using AC contactor, switch off “SELECT Disable” recommended.

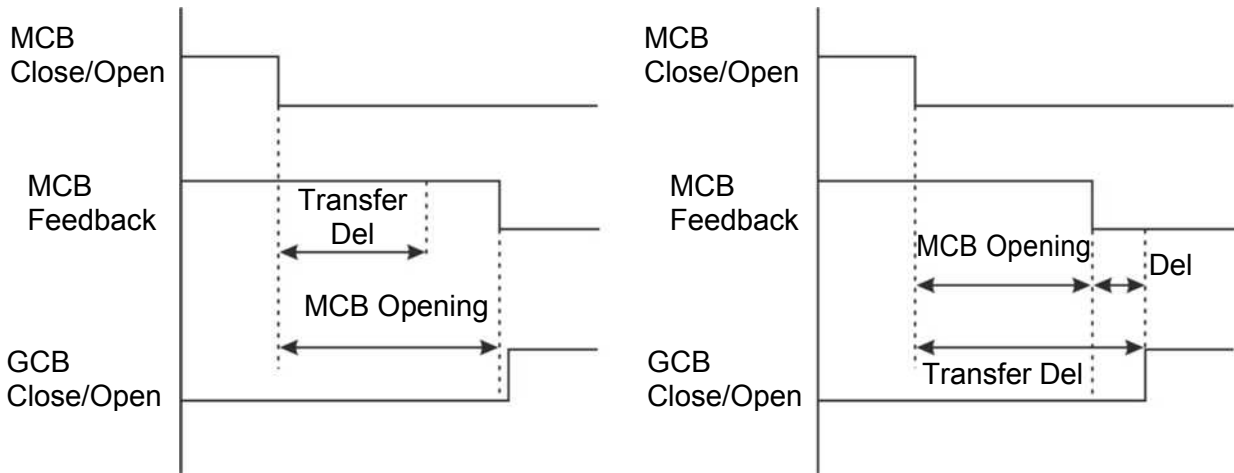

7. SMS remote control、 wireless remote control

GSM Remote control

SMS Code is described as follows

Note:If the operation of the controller, the controller internally set to fly letter phone number can not start with a "+86"

Note:Write text messages are not case sensitive, but must be written in strict accordance with the instructions in the format, the spaces between all the words are a bit of spaces, all commands have to wait until the return code indicates that the operation is valid only.

NO.	SMS Command	SMS return information	Description
1	SMS GENSET	GENSET ALARM	When genset is stopping to alarm
		SYSTEM IN STOP MODE GENSET AT REST	At rest status in stop mode
		SYSTEM IN MANUAL MODE GENSET AT REST	At rest status in stop mode
		SYSTEM IN TEST MODE GENSET AT REST	At rest status in stop mode
		SYSTEM IN AUTO MODE GENSET AT REST	At rest status in stop mode
		SYSTEM IN STOP MODE GENSET IS RUNNING	Running status in stop mode
		SYSTEM IN MANUAL MODE GENSET IS RUNNING	Running status in stop mode
		SYSTEM IN TEST MODE GENSET IS RUNNING	Running status in stop mode
		SYSTEM IN AUTO MODE GENSET AT RUNNING	Running status in stop mode
2	SMS START	GENSET ALARM	Generator is shutdown alarm or trip alarm
		GENSET IS RUNNING	The generator is running
		SMS START INHIBIT	SMS boot prohibited
		STOP MODE NOT START	Cannot start in stop mode
		SMS START OK	Start in manual or auto mode

		AUTO MODE START OK	Can start in auto mode
3	SMS STOP IN AUTO MODE	AUTO MODE STOP OK	In automatic mode shutdown
4	SMS STOP MODE	SMS STOP OK	Set as stop mode
5	SMS MANUAL MODE	SMS MANUAL MODE OK	Set as manual mode
6	SMS TEST MODE	SMS TEST MODE OK	Set as trial test mode
7	SMS AUTO MODE	SMS AUTO MODE OK	Set as auto mode
8	SMS INHIBIT START	INHIBIT START OK	Set as start inhibit
9	SMS PERMIT START	PERMIT START OK	Set as start permit
10	SMS DETAIL	Users check setting (As shown below)	Users can query through a text message multiple generators.

7.1. LXI680 Connection diagram

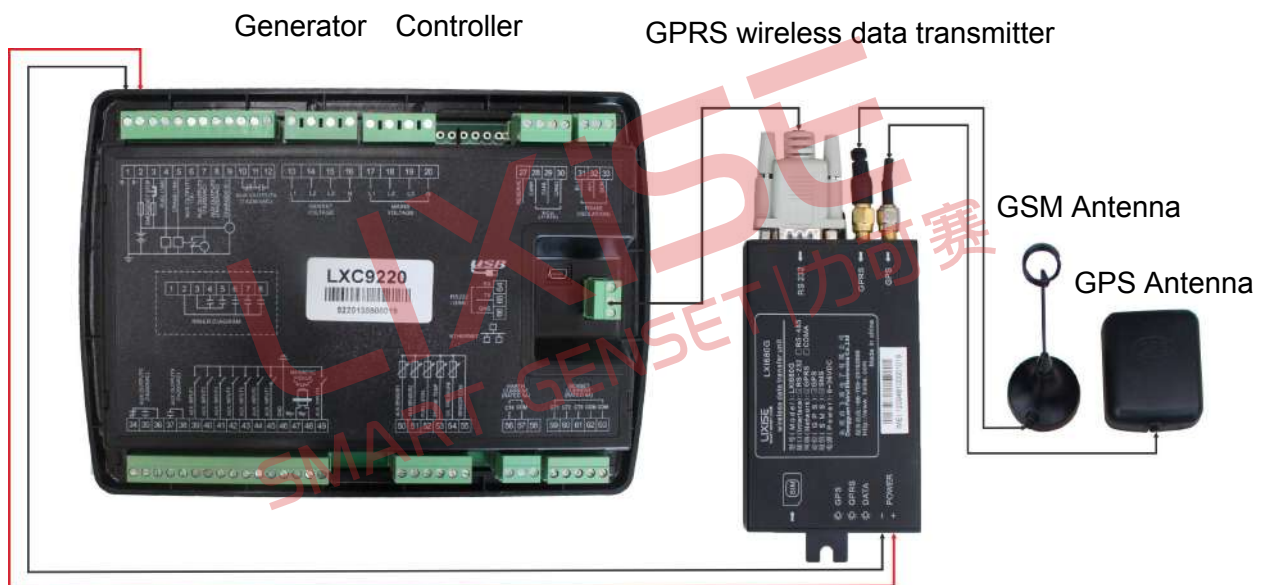

7.2. GSM Alarm setting

As show below 【need to the SMS automatically notify the alarm】 When the user check the condition occurs, the DUT module will automatically send SMS to the user set the cell phone number.

7.3. Based on the GPRS DTU remote online monitoring

- ❖ The scheme is based on LXI680G provide wireless data transmission network, remote control operation of the generator on the Internet; and through the increase in the generator controller LXI680G Room communication protocol, so that the controller can the use of LXI680G SMS via SMS to control the generator run and generators receive alarm SMS.
- ❖ Remark: LXI680G is Dongguan Feirui Electronics Co.,Ltd designed tailor-made for the generator controller wireless data transmission module, in particular to optimize the data exchange between the controller and the DTU, truly a fast and reliable data transmission.
- ❖ Brief introduction:LXI680G is an industrial grade with GPS global satellite positioning function GPRS DTU product. The product integrates a high-performance, low-power industrial-grade GPS module and GPRS module, GPS global positioning technology and GPRS wireless communication technology the perfect combination of a product.
- ❖ LXI680G platform based on ARM and embedded operating system, built-in industrial-grade module, it can be used in harsh environments, working temperature range can be up to -40℃ ~ + 85℃.LXI680G provide standard RS232 serial interface, can be quickly and PLC, industrial control, instruments, meters, RTU equipment is linked together, through the GPRS network will be linked to LXI680G equipment data transmission to a host on the Internet, realize the data remote transparent transmission, at the same time to the front-end equipment of GPS location information reported to host, realize positioning of the equipment.
- ❖ LXI680G with positioning, wireless data communications and data processing capabilities in a compact, rugged, reliable, easy to install, can be widely used in construction, transportation and other industries. Particularly suitable for tower crane monitoring, heavy machinery management, but also can be used in the field of taxi operations management, transport vehicles, special vehicles, vehicle rental management and leasing.

7.4. Wireless connection schematic diagram

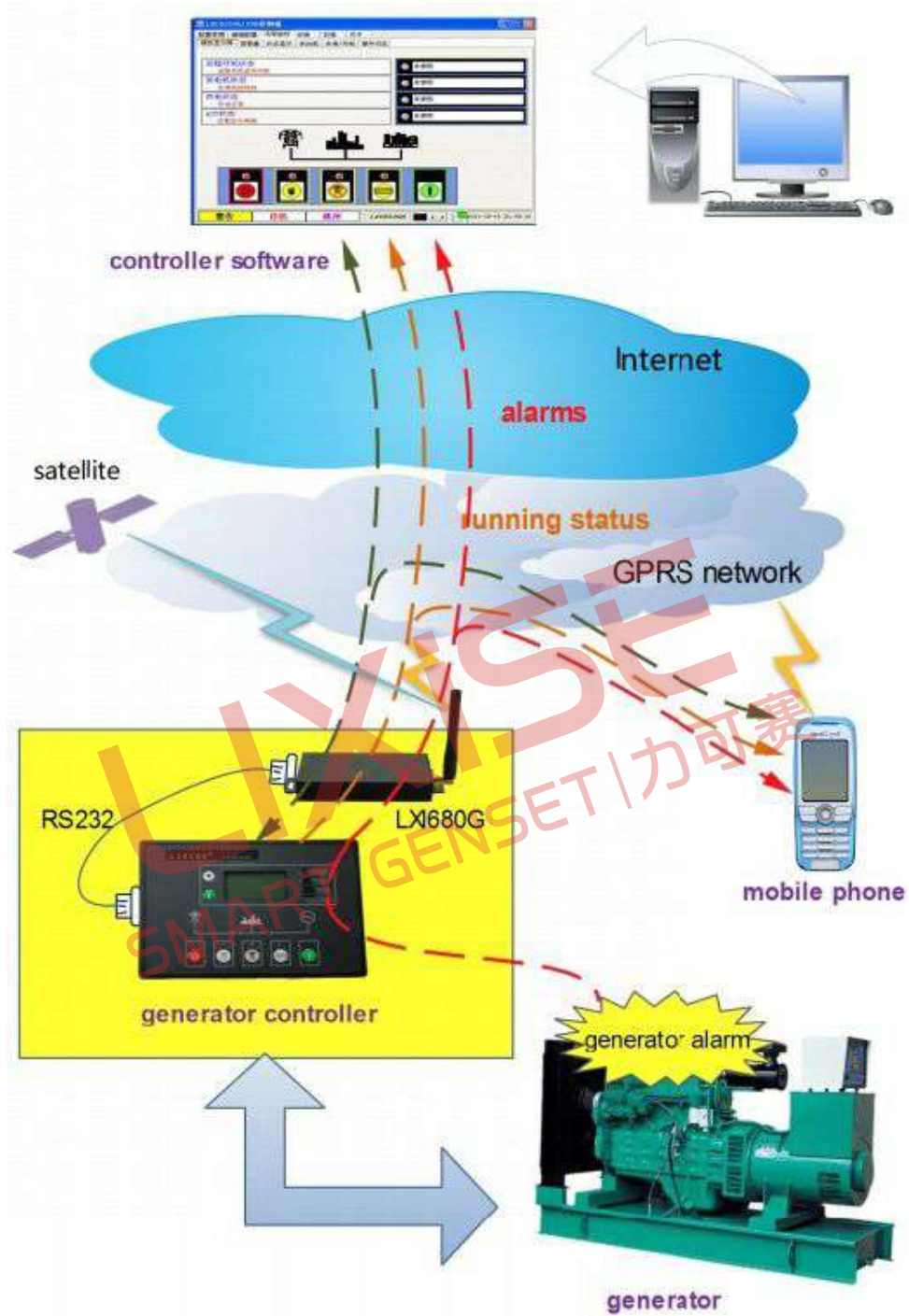

7.5. Connect the controller through the DTU remote

As shown below, Choice in the mode of connection 【 Connected by a data center 】 Can through the Internet remote monitoring state of generator. Details see monitoring software manual.



7.6. DTU with the binding of the controller

Controller and LXI680G after binding, it is only through the password to unbundling, if forced the controller and the DTU apart, the controller will record the alarm and displayed on the LCD panel and the warning information, or refuse the next start generator (the user can set up the binding deal) after failure, this feature is especially suitable for generator leasing industry.

Module password

Alter Module Password(4 digits)

New Technician Pwd:	<input type="text"/>	Alter Technician Pwd
New Operator Pwd:	<input type="text"/>	Alter Operator Pwd

Generate Dynamic Password

Engineer Password(4 digits)	<input type="text"/>	
Request code	<input type="text"/>	Generate->
		Dynamic Password <input style="width: 100px;" type="text"/>

8. History query

8.1.1. Event log

In the control panel buttons to view controller before abnormal downtime record, including the time of the outage warning content display and the state, the controller can record 142 abnormal downtime record recently.

8.1.2. Historical alarm data query

Generator controller will fail instantly record all monitoring parameters, users can remotely view or download, user analyze the cause, because a single record of data is very large, the controller can see the main part of the parameters, other parameters need to access via PC connection . If you need remote access monitoring software through GPRS wireless remote access to data.

History data display window

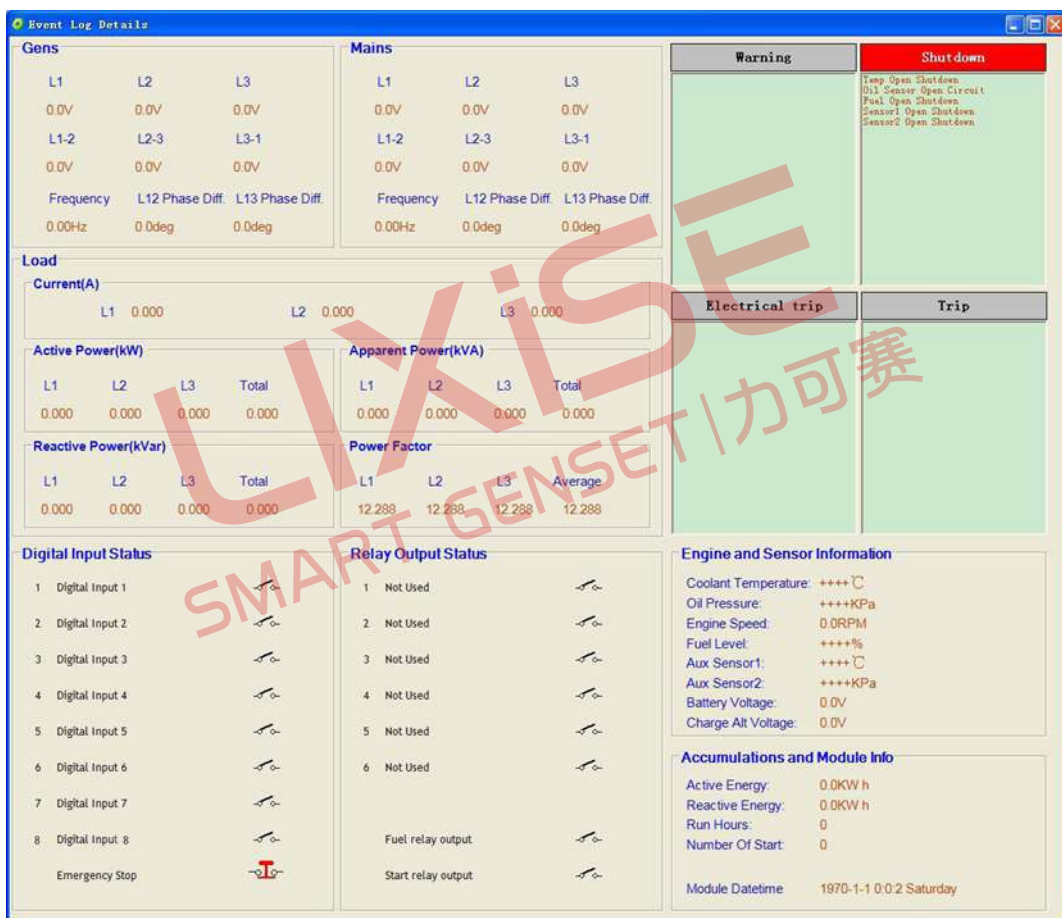

9. Protection

9.1. Shutdown alarm

When controller detects shutdown alarm, it will send signal to stop the generator.
Shutdown alarms as following:

No	Type	Description
1	Emergency Stop	When controller detects emergency stop signal, it will send a stop signal.
2	Over Speed	When controller detects the speed value is higher than the set value, it will send a stop signal.
3	Under Speed	When controller detects the speed value is lower than the set value, it will send a stop signal.
4	Loss Of Speed Signal	When controller detects speed value equals to 0, and the action select "Shutdown", it will send a stop alarm signal.
5	Over Frequency	When controller detects the frequency value is higher than the set value, it will send a stop signal.
6	Under Frequency	When controller detects the frequency value is lower than the set value, it will send a stop signal.
7	Over Voltage	When controller detects the voltage value is higher than the set value, it will send a stop signal.
8	Under Voltage	When controller detects the voltage value is lower than the set value, it will send a stop signal.
9	Fail To Start	If genset start fail within setting of start times, controller will send a stop signal.
10	Over Current	When controller detects the current value is higher than the set value, it will send a stop signal.
11	Current Negative Phase Sequence Shutdown	When the generator current between three-phase load imbalance is greater than the set value, and generating an alarm and shutdown.
12 - 14	Maintenance 1-3 Shutdown	When count down time is 0 and the action select "Shutdown", it will send a stop alarm signal.
15	Reverse Power Shutdown	When controller detects reverse power value (power is negative) is lower than the set value, and the reverse power action select "shutdown", it will send a stop alarm signal.
16	Over Power Shutdown	When controller detects reverse power value (power is positive) is higher than the set value, and the reverse power action select "shutdown", it will send a stop signal.
17	Temp. Sensor Open	When controller detects sensor is open circuit, and the action select "shutdown", it will send a stop signal.
18	High Temp Shutdown	When controller detects temperature is higher than the set value, it will send a stop signal.
19	Pressure Sensor Open	When controller detects sensor is open circuit, and the action select "shutdown", it will send a stop signal.
20	Low OP Shutdown	When controller detects oil pressure is lower than the set value, it will send a stop signal.
21	Level Sensor Open	When controller detects sensor is open circuit, and the action select " shutdown", it will send a stop signal.
22	Low Level Shutdown	When controller detects level is lower than the set value, it will send a stop signal.
23	Flexible Sensor 1 Open	When controller detects sensor is open circuit, and the action select "shutdown", it will send a stop signal.

24	Flexible Sensor 1 High	When controller detects the sensor value is higher than the max. set value, it will send stop signal.
25	Flexible Sensor 1 Low	When controller detects the sensor value is lower than the min. set value, it will send stop signal.
26	Flexible Sensor 2 Open	When controller detects sensor is open circuit, and the action select "shutdown", it will send a stop signal.
27	Flexible Sensor 2 High	When controller detects the sensor value is higher than the max. set value, it will send stop signal.
28	Flexible Sensor 2 Low	When controller detects the sensor value is lower than the min. set value, it will send stop signal.
29	Digital Input Port 1-8	When digital input port 1-8 is set as shutdown, and the action is active, it will send a shutdown signal.
30	D + Open shutdown	Generator starting on the D+ connected to detect if an alarm when open.

9.2. Trip and stop alarm

When controller detects shutdown alarm signal, it will shutdown generator quickly and stop after high speed cooling.

Trip and stop alarm as following:

Trip and stop alarm		
No.	Type	Description
1	Over Current	When controller detects the value is higher than the set value, and the action select "trip and shutdown", it will send trip and stop signal.
2	Current Negative Phase Sequence	When the generator is three-phase load imbalance between the current and larger than the set value, generating a trip and downtime.
3	Maintenance1-3	When count down time is 0 and the action select "trip and shutdown", it will send a trip and stop signal.
6	Reverse Power	When controller detects reverse power value (power is negative) is lower than the set value, and the action select "trip and shutdown", it will send a trip and stop signal.
7	Over Power	When controller detects the over power value (power is positive) is higher than the set value, and the action select "trip and shutdown", it will send a trip and stop signal.
8	Low Fuel	When a trip is generated when the fuel level is low and shut down.
9	Digital Input Ports 1-8	When digital input port1-8 is set as "trip and shutdown", and the action is active, it will send a trip and stop signal.

9.3. Trip alarm

When controller detects trip alarm, it will break close generator signal quickly, but genset not stop. Trip alarm as following:

Trip alarm		
No.	Type	Description
1	Over Current	When controller detects the value is higher than the set value, and the action select "trip", it will send trip signal.
2	Current Negative Phase Sequence	When the generator 3 phase load current is greater than the set value of balance and a trip but non-stop.
3	Reverse Power	When controller detects reverse power value (power is negative) is lower than the set value, and the action select "trip", it will send a trip signal.
4	Over Power	When controller detects the over power value (power is positive) is higher than the set value, and the action select "trip", it will send a trip signal.
5	Low Fuel	When the generator current between three-phase load imbalance is greater than the set value, and generating a trip is not shut down.
6	Digital Input Ports1-8	When digital input port1-8 is set as "trip", and the action is active, it will send a trip signal.

9.4. Warnings

When controller detects the warning signal, alarm only and not stop genset. Warnings as following:

Warnings		
No.	Type	Description
1	Over Speed Warn	When controller detects the speed is higher than the set value, it will send warn signal.
2	Under Speed Warn	When controller detects the speed is lower than the set value, it will send warn signal.
3	Loss of Speed Signal Warn	When controller detects the speed is 0 and the action select "Warn", it will send warn signal.
4	Over Frequency Warn	When controller detects the frequency is higher than the set value, it will send warn signal.
5	Under Frequency Warn	When controller detects the frequency is lower than the set value, it will send warn signal.
6	Over Voltage Warn	When controller detects the voltage is higher than the set value, it will send warn signal.
7	Under Voltage Warn	When controller detects the voltage is lower than the set value, it will send warn signal.
8	Over Current Warn	When controller detects the current is higher than the set value, it will send warn signal.
9	Current Negative Phase Sequence Warn	When the generator is an imbalance between the three phase load current and greater than the set value only a warning.
10	Fail to Stop	When generator not stops after the "stop delay" is over.

11	Charge Alt Fail	When controller detects the charger voltage is lower than the set value, it will send warn signal.
12	Battery Over Voltage	When controller detects the battery voltage is higher than the set value, it will send warn signal.
13	Battery Under Voltage	When controller detects the battery voltage is lower than the set value, it will send warn signal.
14	Maintenance1-3 warn	When count down time is 0 and the action select "Warn", it will send warn signal.
17	Reverse Power	When controller detects the reverse power value (power is negative) is lower than the set value, it will send warn signal.
18	Over Power	When controller detects the reverse power value (power is positive) is higher than the set value, it will send warn signal.
19	Gen Loss of Phase	When controller detects the generator loss phase, it will send warn signal.
20	Gen Phase Sequence Wrong	When controller detects the reverse phase, it will send warn signal.
21	Gen load Close Fail	When the controller gen start closing state input is detected, the default close delay is not detected, the issue of closing failure warning. This warning does not automatically eliminated. (You can press the mute button to eliminate)
22	Main Load Close Fail	When the controller main start opening state input is detected, the default open delay is not detected, the issue of opening failure warning. This warning does not automatically eliminated. (You can press the mute button to eliminate)
23	Gen Load Open Fail	When the controller gen start opening state input is detected, the default open delay is not detected, the issue of opening failure warning. This warning does not automatically eliminated. (You can press the mute button to eliminate)
24	Main Load Open Fail	When the controller main start opening state input is detected, the default open delay is not detected, the issue of opening failure warning. This warning does not automatically eliminated. (You can press the mute button to eliminate)
25	Temp. Sensor Open	When controller detects the sensor is open circuit, and the action select "warn", it will send warn signal.
26	High Temp. Warn	When controller detects the temperature is higher than the set value, it will send warn signal.
27	Low Temp. Warn	When controller detects the temperature is lower than the set value, it will send warn signal.
28	Oil Pressure Sensor Open	When controller detects the sensor is open circuit, and the action select "warn", it will send warn signal.
29	Low OP Warn	When controller detects the oil pressure is lower than the set value, it will send warn signal.
30	Level Sensor Open	When controller detects the sensor is open circuit, and the action select "warn", it will send warn signal.
31	Low Level Warn	When controller detects the oil lever is lower than the set value, it will send warn signal.
32	Flexible Sensor 1 Open	When controller detects the sensor is open circuit, and the action select "warn", it will send warn signal.

33	Flexible Sensor 1 High	When controller detects the sensor value is higher than the max. set value, it will send warn signal.
34	Flexible Sensor 1 Low	When controller detects the sensor value is lower than the min. set value, it will send warn signal.
35	Flexible Sensor 2 Open	When controller detects the sensor is open circuit, and the action select "warn", it will send warn signal.
36	Flexible Sensor 2 High	When controller detects the sensor value is higher than the max. set value, it will send warn signal.
37	Flexible Sensor 2 Low	When controller detects the sensor value is lower than the min. set value, it will send warn signal.
38-44	Digital Input 1-8 Warn	When digit input port 1-8 is set as warning and active, controller sends corresponding warning signal.
45	DTU Bonding Fail	When Set DTU binding, the controller and the DTU communication failure display instructions.

10. Wirings

LXC9210, LXC9220 controller's rear as following:

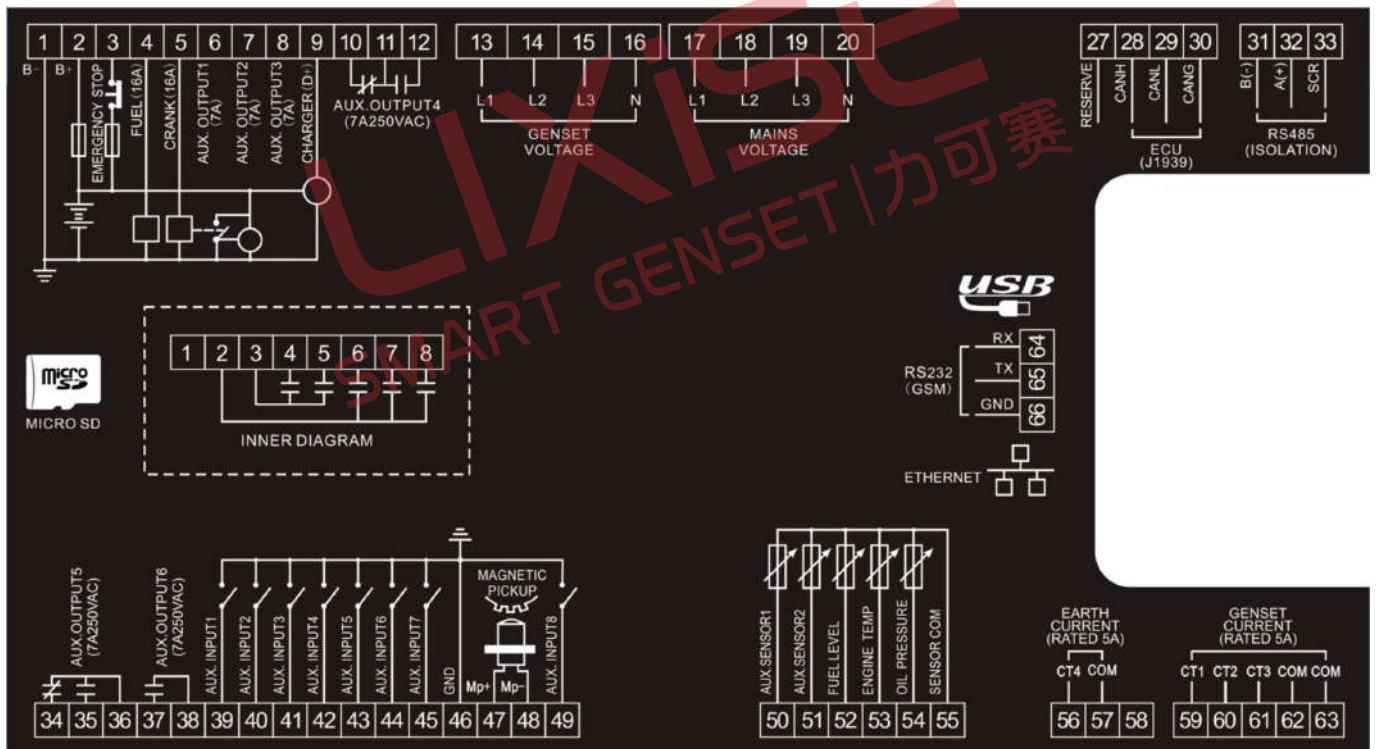

No.	Functions	Functions	Remark
1	DC input B-	2.5mm	DC Power Supply negative input, external starter battery's negative.
2	DC input B+	2.5mm	DC Power Supply positive input of the the external starter battery positive, it is recommended to use 20A fuse.
3	Emergency stop	2.5mm	DC voltage through the emergency stop button connected equipment supplied to the fuel and starter relay output, recommended maximum 30A fuse.
4	Fuel relay output	1.5mm	By the 3-terminal DC voltage supply, rated current 16A
5	Start relay output	1.5mm	By the 3-terminal DC voltage supply, rated current 16A
6	Aux. Output 1	1.5mm	By the B + supply output Rated current 7A
7	Aux. Output 2	1.5mm	
8	Aux. Output 3	1.5mm	
9	Charger(D+)	1.0mm	Connect to charge generators D+ (WL) terminals. Being hang up If there is no the terminal.
10	Aux. Output 4	1.5mm	Normally close outputs, rated 7A
11		1.5mm	Public points of relay
12		1.5mm	Normally open outputs, rated 7A.
13	Genset A-phase voltage sensing input	1.0mm	Genset A-phase voltage sensing input
14	Genset B-phase voltage sensing input	1.0mm	Connect to B-phase of gen-set (2A fuse is recommended).
15	Genset C-phase voltage sensing input	1.0mm	Connect to C-phase of gen-set (2A fuse is recommended).
16	Gen-set N-wire input	1.0mm	Connected to N-wire of gen-set
17	Mains A-phase voltage sensing input	1.0mm	Connect to A-phase of mains (2A fuse is recommended) (LXC9210 without).
18	Mains B-phase voltage sensing input	1.0mm	Connect to B-phase of mains (2A fuse is recommended)(LXC9210 without).
19	Mains C-phase voltage sensing input	1.0mm	Connect to C-phase of mains (2A fuse is recommended)(LXC9210 without).
20	Mains N-wire input	1.0mm	Connected to N-wire of mains (LXC9210 without).
27	Spare		
28	CAN+	0.5mm	Impedance-120Ω shielding wire is recommended, its single-end earthed. (controllers without RS485 don't have this terminal)
29	CAN-	0.5mm	
30	CAN COM	0.5mm	
31	RS485-	0.5mm	
32	RS485+	0.5mm	
33	RS485 COM	0.5mm	
34	Aux. Output 5 (7A250VAC)	1.5mm	Normally close outputs, rated 7A
35		1.5mm	Normally open outputs, rated 7A.
36		1.5mm	Public points of relay
37	Aux. Output 6 (7A250VAC)	1.5mm	Normally open outputs, rated 7A.
38		1.5mm	Public points of relay
39	Aux. Input 1	1.0mm	Ground connected is active (B-).
40	Aux. Input 2	1.0mm	
41	Aux. Input 3	1.0mm	
42	Aux. Input 4	1.0mm	

43	Aux. Input 5	1.0mm	
44	Aux. Input 6	1.0mm	
45	Aux. Input 7	1.0mm	
46	GND	1.0mm	
47	Magnetic pickup	0.5mm	Connected to Magnetic Pickup, shielding line is recommended
48	Magnetic pickup input, and controller inner be connected to battery negative.	0.5mm	Common ground, which can be accessed chassis or starter battery negative
49	Aux. Input 8	1.0mm	Ground connected is active (B-).
50	Configurable sensor 1	1.0mm	Connect to temperature, oil pressure or fuel level sensors.
51	Configurable sensor 2	1.0mm	
52	Fuel level sensor	1.0mm	Connect to oil pressure sensor
53	Temperature sensor	1.0mm	Connect to temperature sensor
54	Oil pressure sensor	1.0mm	Connect to oil pressure sensor
55	Sensor COM	1.0mm	Public terminals of sensor, (B-) have already connected.
56	Earth Current Input	1.5mm	Outside connected to secondary coil of current transformer(rated 5A)
57	Earth Current Input	1.5mm	
58	Spare		
59	CT A-phase sensing input	1.5mm	Outside connected to secondary coil of current transformer(rated 5A)
60	CT B-phase sensing input	1.5mm	Outside connected to secondary coil of current transformer(rated 5A)
61	CT C-phase sensing input	1.5mm	Outside connected to secondary coil of current transformer(rated 5A)
62	CT COM	1.5mm	See following installation instructions.
63	CT COM	1.5mm	
64	RS232 RX	0.5mm	Recommended to use shielded cable, the shield single-grounded (No SMS function controller without these terminals)
65	RS232 TX	0.5mm	
66	RS232 COM	0.5mm	

✧ **NOTE:** Back USB interface for programming interface parameters, can be directly using a computer programming of the USB cable to the controller, the controller without external power supply.

 **NOTE:** Prohibited during operation of the engine starter batteries removed, otherwise it will cause the control system due to excessive DC input voltage and burned!

11. Parameters setting

11.1. Basic configuration parameters

❖ **The controller has 2 different password:**

Technician Password: Default password: 0000;

Operator password : Default password: 1111;

❖ **Password Privilege Description:**

Technician Password: Has the authority to modify all parameters.

Operator password: You can view the parameters of the project, do not have permission to modify parameters.

❖ **If there is need to set more parameters, please contact the factory.**

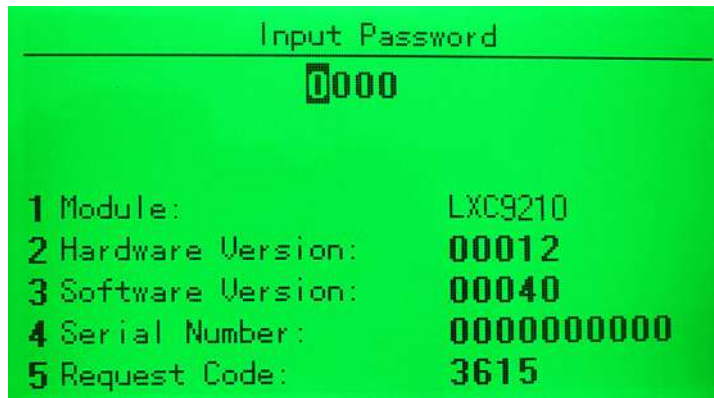

When the configuration parameters to the user, by inputting different permissions password, the controller will show different parameter configuration interface.

11.2. Basic configuration

NOTE: LXC7X10 controller no items of mains in setting and also no mains items in configurable ports of input/output.

NOTE: Please set the generator frequency value as low as possible when cranking, in order to make the starter be separated quickly as soon as crank disconnect.

















CAUTION: Please change the controller parameters when generator is in stand-by mode only otherwise, alarming to stop and other abnormal conditions may happen.

In the parameter display long press for more than 3 seconds  key, you can enter the basic parameters of the configuration interface.

Basic configuration parameter			
No.	Items	Defaults	Description
1	Language Selection:	Chinese	The controller display language set
2	Mains detect Options:	Enable	The mains condition monitoring settings
3	Mains Rated Voltage (30-30000V):	00230	Standard for checking mains over/under voltage. (This value is primary voltage of transformer).
4	Mains Rated Freq (10-65Hz):	50.0	Standard for checking mains over/under frequency.
5	Quick load:	Ban	
6	Crank Disconnect	6.Oil pressure + speed + generator	Conditions of disconnecting starter with engine. Each condition can be used alone and simultaneously.
7	Flywheel Teeth(10-300):	118	Teeth number of the engine for judging of starter disconnection and inspecting speed of engine.
8	Rated Speed (0-6000RPM):	1500	Offer standard to judge over /under/ loading speed.
9	Gen Rated Volt (30-30000V):	00230	Offer standards for detecting of gens' over/under voltage and loading volt.If using voltage transformer, this value is primary volt of transformer.
10	Gen Rated Freq	50.0	Offer standards for detecting of over/ under /load

	(10-65Hz):		frequency.
11	Curr Transform (6000/5A):	0500	The change of external connected CT.
12	Rated Current(5-6000A):	0500	Generator's rated current, standard of load current.
13	Rated Power(KW):	0276	Generator's rated power, standard of load current.
14	Battery Rated Volt (0-600V):	24.0	Standard for detecting of over/under voltage of battery.
15	Module Date:	User Setting	
16	Module Clock:	User Setting	
17	Start Delay (0-3600s):	0003	Time from mains abnormal or remote start signal is active to start genset.
18	Stop Delay (0-3600s):	0003	Time from mains normal or remote start signal is inactive to genset stop.
19	Return Delay (0-3600s):	0003	
20	Preheat Delay (0-3600s):	0005	Time of pre-powering heat plug before starter is powered up.
21	Cranking Time (3-60s):	05	Time of starter power up each time.
22	Crank Rest Time (3-60s):	05	The second waiting time before power up when engine start fail.
23	Safety On Delay (0-3600s):	0005	Alarms for low oil pressure high temp , under speed, under frequency/ voltage , charge fail are inactive.
24	Start Idle Time (0-3600s):	0005	Idle running time of genset when starting.
25	Warming Up Time (0-3600s):	0005	Warming time before genset switch on , after it into high speed running.
26	Cooling Time (0-3600s):	0005	Radiating time before genset stop, after it unloads.
27	Stop Idle Time(0-3600s):	0005	Idle running time when genset stop.
28	ETS Hold Time (0-3600s):	0005	Stop electromagnet's power on time when genset is stopping.
29	Wait Stop Time (0-3600s):	0005	
30	After Stop Time (0-3600s):	0002	
31	Controller information:	Product version information	

11.3. Advanced configuration parameter

In the controller main interface, press  and  key, enter the password input interface, press  or  key to enter the corresponding bit password(0-9), press   shift, after the completion of the input  proofreading password, the password is correct according to the different permissions password to enter the main interface of the parameters of the different permissions, the password error exit. (The factory default password is: 0000) The factory default password the user can modify. Press  and  keys can flip up and down the parameters configuration screen operation, under the currently selected configuration parameter, press the  key, to the current configuration mode parameters, the current value of the first black display, press  or  keys for the bit value adjustment, press   key to shift, press the  keys to confirm the Settings. This value is permanently saved to the internal FLASH controller. Configuration process, press  to return to the previous menu or long press  to exit the configuration menu to return to the main screen.

11.4. Defined contents of configurable input ports

No.	Type	Description
1	Users Configured	Including following functions: ----- Warning: warn only, not shutdown. Shutdown: alarm and shutdown immediately. Trip and stop: alarm, generator unloads and shutdown after hi-speed cooling. Trip: alarm, generator unloads but not shutdown. Indication: indicate only, not warning or shutdown. ----- From safety on: detecting after safety on run delay. From crank: detecting as soon as start. Always: input is active all the time. Never: input inactive
2	Alarm Mute	Can prohibit "Audible Alarm" output when input is active.
3	Reset Alarm	Can reset shutdown alarm and trip alarm when input is active.
4	Aux High Temp	Connected sensor digital input.
5	Aux Low OP	Connected sensor digital input.
6	Inhibit Alarm Stop	Prohibit any alarm and shutdown action.
7	Remote Start On Load	In Auto mode, when input active, genset can be started and with load after genset is OK; when input inactive, genset will stop automatically.
8	Remote Start Not On Load	In Auto mode, when input is active, genset can be started and without load after genset is OK; when input is inactive, genset will stop automatically.
9	Aux Manual Start	In Auto mode, when input active, genset will start automatically; when input inactive, genset will stop automatically.
10	Simulation Mains OK	In Auto mode, mains are normal when input is active.
11	Simulation Mains Fail	In Auto mode, mains are abnormal when input is active.
12	Panel Lock	Generator related operations are banned, switch query interface can be used.
13	Inhibit Auto Stop	In Auto mode, during generator normal running, when input is active,

		inhibit generator shutdown automatically.
14	Inhibit Auto Start	In Auto mode, inhibit generator start automatically when input is active.
15	Inhibit Scheduled	In Auto mode, inhibit scheduled run genset when input is active.
16	Inhibit Phone Message Start	Prohibiting boot via SMS.
17	Inhibit Gens Load	Prohibit genset switch on when input is active.
18	Inhibit Mains Load	Prohibit mains switch on when input is active.
19	Auto Mode Lock	When the input is active, the controller will operate in automatic mode, you can not select the test mode and manual mode.
20	Auto Mode Invalid	When input is active, controller won't work under Auto mode. AUTO key and simulate auto key input does not work.
21	Idle Control Mode	Under voltage/frequency/speed protection is inactive.
22	Instrument Mode	All outputs are prohibited in this mode.
23	Aux Gens Closed	Connect generator loading switch's Aux. Point.
24	Aux Mains Closed	Connect mains loading switch's Aux. Point.
25	Aux Raise Speed	This configuration is for the use of motor adjust the speed of the unit, and raise speeding output with control motor. When this switch is closed, raise speed output will turn off.
26	Aux Drop Speed	This configuration is for the use of motor adjust the speed of the unit, and drop speeding output with control motor. When this switch is closed, raise speed output will turn off.
27	Reset Maintenance	Controller will set maintenance time and date as default when input is active.
28	Simulate Stop key	An external button can be connected and pressed as simulate panel.
29	Simulate Manual key	
30	Simulate Manual Test key	
31	Simulate Auto key	
32	Simulate Start key	
33	Simulate G-Load key	
34	Simulate M-Load key	
35	Lamp Test	All LED indicators are illuminating when input is active.
36	60Hz Active	Use for CANBUS engine and it is 60Hz when input is active.
37-39	Alternative Config1-3	Users can set different parameters to make it easy to select current configuration via input port.

11.5. Enable definition of programmable output ports

No.	Type	Description
0	Not Used	
1	Fuel Relay	Action before the starter motor, open the fuel system in advance. Usually controls the governor's power and fuel solenoid valve.
2	Crank Relay	When starting the motor action, often connected to the starter relay.
3	Air Flap	Action in over speed alarm stop and emergence stop. It also can close the air inflow the engine.
4	Audible Alarm	Action in warning, shutdown, trips. Can be connected outside alarm. When programmable input port is active of "alarm mute", can prohibit its output.
5	Louver Control	Action in genset starting and disconnect when genset stopped completely.
6	Fuel Pump Control	It is controlled by fuel pump of level sensor's limited threshold.
7	Heater Control	It is controlled by heating of temperature sensor's setting bound.
8	Cooler Control	It is controlled by cooler of temperature sensor's setting bound.
9	Pre-oil Supply Output	Action from "crank on" to "safety on".
10	Excite Generator	Output in start period. If there is no gens frequency during hi-speed running, output 2 seconds again.
11	Pre-Lubricate	Actions in period of pre-heating to safety run.
12	Remote PC Output	This port is controlled by communication (PC).
13	Idle Control	Used for engine which has idles. Pull in before starting and pull out after into hi-speed warming; Pull in during stopping idle mode and pull out after shutdown completed.
14	Raise Speed	Action in hi-speed warming run.
15	Drop Speed	Action in period of stop idle mode to time of wait for stopping completely.
16	Reserved	
17	Reserved	
18	ETS Control	Used for engines with ETS electromagnet. Pull in when stop idle is over and pull out when set "ETS delay" is over.
19	Close Generator	Generator load conditions are ripe for action, control power closing switch with load. It is a continuous output.
20	Open Generator Pulse	The same role, but is not a continuous output, but only the output pulses of a preset time. This time set in the timer configuration.
21	Open Generator	Generator stop action, control power generation closing switch uninstal.
22	Open Generator Pulse	The same role, but is not a continuous output, but only the output pulses of a preset time. This time set in the timer configuration.
23	Open Breaker	Gens whether or mains is opened, will be output. It is a common sub-gate output.
24	Close Mains	Control switch of mains is load.
25	Close Mains Pulse	
26	Open Mains	
27	Open Mains Pulse	
28	Reserved	
29	Generator OK	Action when gens are normal.
30	Generator Available	Action in period of gens ok to hi-speed cooling.
31	ECU Stop	Used for ECU engine and control its stop.
32	ECU Power	Used for ECU engine and control its power.
33	Crank Success	Pull in when detects a successful start signal.
34	GSM Power	Power for GSM module (GSM module is power-off reset when GSM

		communication failed).
35	Mains OK	Action when mains normal.
36	In Stop Mode	
37	In Manual Mode	
38	In Manual Test Mode	
39	In Auto Mode	
40	Generator On Load	
41	Mains On Load	
42	Reserved	
43	Common Alarm	Action in gens common warning, common shutdown, common trips alarm.
44	Common trip shutdown	The generators any kind of trip and downtime will produce such an alarm action.
45	Common Shutdown	Generator any downtime will have such alarm action.
46	Common Trip Alarm	Generators will produce any kind of trip the alarm action.
47	Common Warn Alarm	Generators of any kind of public warning alarm is generated action.
48	Battery Hight Voltage	An action in battery's over voltage warning alarm.
49	Battery Low Voltage	Action in battery's low voltage warning alarm.
50	Charging failure	Action in charge alt fail warning alarm.
51	ECU Warn	Indicate ECU sends a warning alarm signal.
52	ECU Shutdown	Indicate ECU sends a shutdown alarm signal.
53	ECU Communication Fail	Indicate controller not communicates with ECU.
54	Emergency Stop	Action in emergency stop alarm.
55	Failed To Start	Action in failed start alarm.
56	Failed To Stop	Action in failed stop alarm.
57	Under Speed Warn	Action in under speed warning.
58	Under Speed Shutdown	Action in under speed shutdown.
59	Over Speed Warn	Action in over speed warning.
60	Over Speed Shutdown	Action in over speed shutdown alarm.
61	Gens Over Freq Warn	Action in gens over frequency warning.
62	Gens Over Freq Shutdown	Action in gens over frequency shutdown alarm.
63		Action in gens over voltage warning.
64	Gens Over Volt Warn	Action in gens over voltage shutdown.
65	Gens Over Volt Shutdown	Action in gens low frequency warning.
66	Gens Under Freq Warn	Action in gens low frequency shutdown.
67	Gens Under Voltage Warn	Action in gens low voltage warning.
68	Gens Under Volt Shutdown	Action in gens low voltage shutdown.
69	Gens Loss Of Phase	Action in gens loss phase.
70	Gens Reverse Phase	Action in gens reverse phase.
71	Over Power	When the load power exceeds a preset value action is to prevent excessive damage to the engine power.
72	Reverse Power	Action in controller detects gens have reverse power.
73	Over Current	Action in over current.
74	Mains Inactive	Action in mains Inactive .
75	Mains Over Freq	Action in mains over frequency.
76	Mains Over Voltage	Action in mains over Voltage.
77	Mains Under Freq	Action in mains under frequency.
78	Mains Under Volt	Action in mains under Voltage.

79	Mains Reverse Phase	When phase sequence of 3 phase input mistake.
80	Mains Loss Of Phase	Action in mains loss Of Phase.
81	High Temp Warn	Action in high temperature warning alarm.
82	Low Temp Warn	Action in low temperature warning alarm.
83	High Temp Shutdown	Action in high temperature Shutdown alarm.
84	Low Oil Pressure Warn	Action in low oil pressure warning alarm.
85	Low Oil Pressure Shutdown	Action in low oil pressure shutdown.
86	OP Sensor Open	Action when oil pressure sensor are open circuit.
87	Low Level Warn	Action when controller has low oil level alarm.
88	Config1 High Warn	
89	Config1 Low Warn	
90	Config1 High Shutdown	
91	Config1 Low Shutdown	
92	Config2 High Warn	
93	Config2 Low Warn	
94	Config2 High Shutdown	
95	Config2 Low Shutdown	
96-102	Aux Input 1-7 Active	
103	Reserved	
104-109	Custom Period 1-6	
110-115	Custom Combined 1-6	

11.6. Defined period output

Defined Period output is made of 2 parts, period output S1 and condition output S2 .



While S1 and S2 are TRUE synchronously, OUTPUT;

While S1 or S2 is FALSE, NOT OUTPUT;

Period output S1, can set generator's one or more period output freely, can set the delayed time and output time after into period.

Condition output S2; can set as any conditions in output ports .

▲ NOTE: when delay time and output time both are 0 in period output S1, it is TRUE in this period .

Example:

Output period: start

Delay output time: 5s

Output time: 3s

Condition output contents: output port 1 is active (Valid / Invalid: close when active/disconnect when inactive)

Output port 1 active, after enter "starts time" and delay 5s, this defined period output is outputting, after 3s, stop outputting.

As shown below





CUSTOM COMBINED OUTPUT

Defined combination output is composed by 3 parts, condition output S1 or S2 and condition output S3.

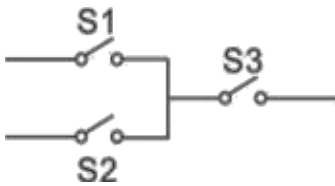

S1 or S2 is TRUE, while S3 is TRUE, Defined combination output is outputting;
S1 and S2 are FALSE, or S3 is FALSE, Defined combination output is not outputting.

▲ NOTE: S1, S2, S3 can be set as any contents except for “defined combination output” in the output setting..

▲ NOTE: 3 parts of defined combination output (S1, S2, S3) couldn't include or recursively include themselves.

Example:

Contents of probably condition output S1: output port 1 is active;
Close when probably condition output S1 is active /inactive: close when active (disconnect when inactive);
Contents of probably condition output S2, output port 2 is active;
Close when probably condition output S2 is active /inactive: close when active (disconnect when inactive);

The closed output S3 valid / invalid and conditions: when active (disconnect when inactive)

When input port 1 active or input port 2 active, if input port 3 is active, Defined combination output is outputting; If input port 3 inactive, Defined combination output is not outputting;

When input port 1 inactive and input port 2 inactive, whatever input port 3 is active or not, Defined combination output is not outputting.

As shown below

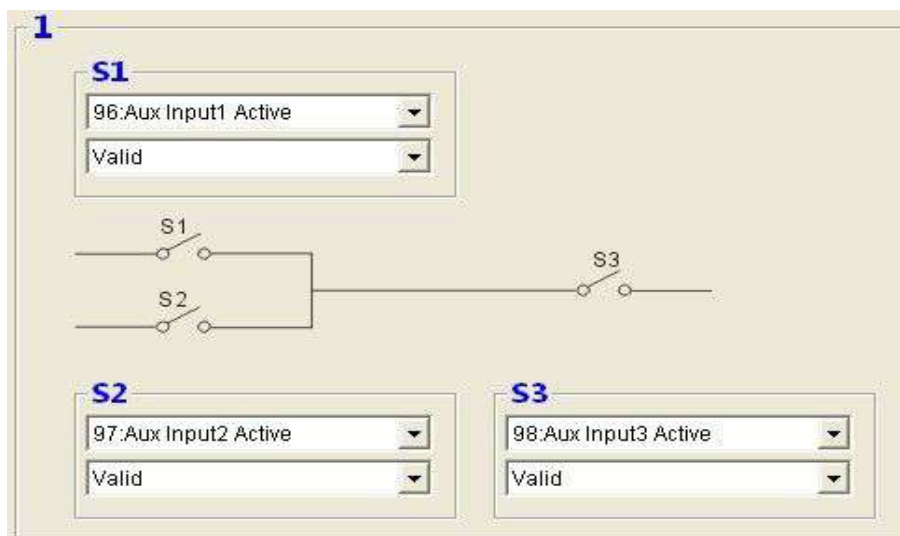

11.7. Sensor selection list

Temperature Sensor	Oil Pressure Sensor	Level Sensor
0 Not used	0 Not used	0 Not used
1 VDO 120°C	1 VDO0-10BAR	1 VDO 0-180ohm
2 CURTIS	2 CURTIS	2 SGD
3 VOLVO-EC	3 VOLVO-EC	3 SGH
4 DATCON	4 DATCON 10BAR	4 Custom Res Curve
5 SGX	5 SGX	5 Custom 4-20mA curve
6 SGD	6 SGD	6 Reserved
7 SGH	7 SGH	7 Reserved
8 PT100	8 Custom Res Curve	8 Reserved
9 Custom Res Curve	9 Custom 4-20mA curve	9 Reserved
10 Custom 4-20mA curve	10 Reserved	10 Reserved
11 Reserved	11 Reserved	11 Reserved
12 Reserved	12 Reserved	12 Reserved

11.8. Pressure unit conversion table

Unit	N/m ² Pa	kg/cm ²	bar	1b/in ² .psi
1Pa	1	1.02 × 10 ⁻⁵	1 × 10 ⁻⁵	1.45 × 10 ⁻⁴
1kgf/cm ²	9.8 × 10 ⁴	1	0.98	14.2
1Bar	1 × 10 ⁵	1.02	1	14.5
1Psi	6.89 × 10 ³	7.03 × 10 ⁻²	6.89 × 10 ⁻²	1

NOTE:

1. Is there a difference if standard curve of sensor with the use of sensors, can be change by itself in the custom curve, when the sensor selection is "no", the curve of sensor doesn't work.
2. If the corresponding sensors, only alarm switch, is the sensor must be set to "no", otherwise likely stop alarm or warning.

11.9. Conditions of crank disconnect selection

As shown above, check the desired options, multiple choice or do not choose.

- ❖ There are 4 conditions to make starter disconnected with engine, that is, speed sensor, generator frequency, Charge D+ and engine oil pressure. They all can be used separately. We recommend that engine oil pressure should be used with speed sensor and generator frequency together, in order to make the starter motor separated with engine immediately and can check crank disconnect exactly.
- ❖ Speed sensor is the magnetic equipment which is installed in the starter for detecting flywheel teeth.
- ❖ When set as speed sensor, must ensure that the number of flywheel teeth is the same as the setting, otherwise, "over speed stop" or "under speed stop" may be caused.
- ❖ If genset without speed sensor, please don't select corresponding items, otherwise, "start fail" or "loss speed signal" may be caused.
- ❖ If genset without oil pressure sensor, please don't select corresponding items.
- ❖ If not select generator in crank disconnect setting, controller will not collect and display the relative power quantity (can be used in water pump set); if not select speed sensor in crank disconnect setting, the rotating speed displayed in controller is calculated by generator frequency and number of poles.
- ❖ If the generator without magneto-electric sensor and oil pressure sensor, the "Charger D+" is optional as a starter motor separation condition. It is recommended to select "Oil Pressure + Charger D+" for safety.

12. Typical application

- ❖ Three kinds of remote controllers are recommended: **Dongguan Feirui Electronics Co.,Ltd**, wireless data transmission equipment DTU680G. The product has wireless data transmission, GPS location data, as long as there is a cell phone signal can be transmitted through the mobile phone network, innovation and independent R & D, dedicated communication module, an infinite distance, data security and reliability features.
- ❖ If the engine starter battery voltage is 24V, measuring starter output port, output port and stop the fuel outlet (based on user configuration dependent) on the battery negative resistance should not be less than 2 ohms, if less than 2 ohms in the corresponding current output port another extension greater than 30A relay. If the engine starter battery voltage is 12V, output measurement start, fuel output port and output port shutdown on battery negative resistance should not be less than 1 ohm, if less than 1 ohm in the corresponding output current is greater than another extension 30A relay.

Three-phase three-wire connection wiring diagram (to LXC9220 example)

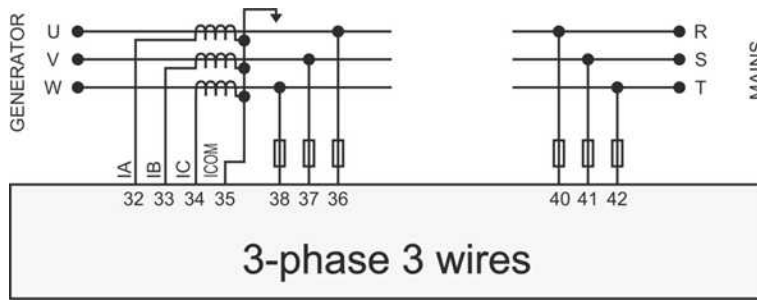

Single-phase two-wire connection wiring diagram (to LXC9220 example)

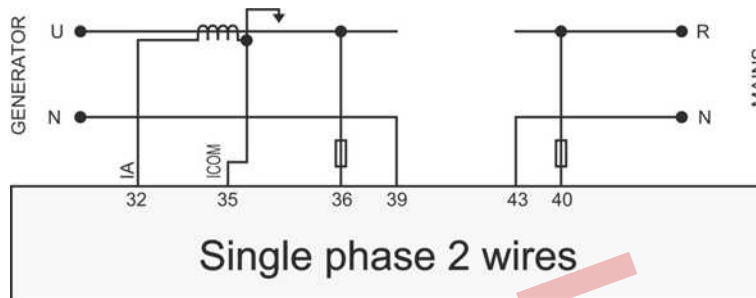

Two-phase three-wire connection wiring diagram (to LXC9220 example)

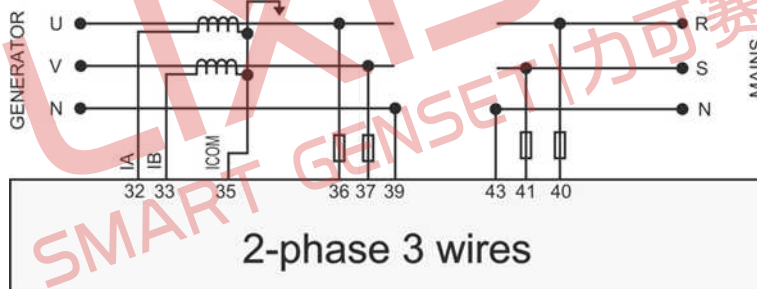

LXC9210 Typical application diagram

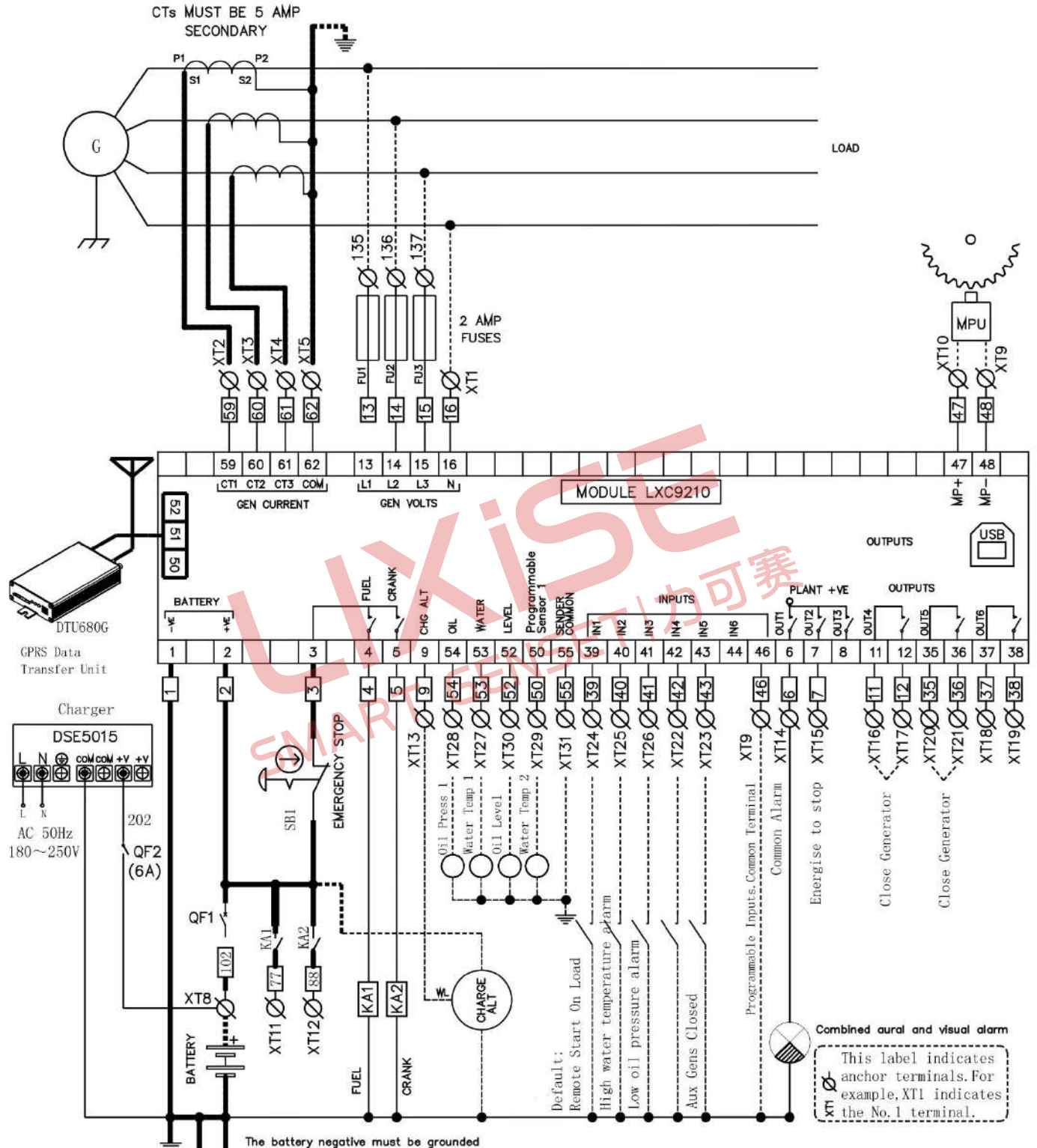

LXC9220 Typical application diagram

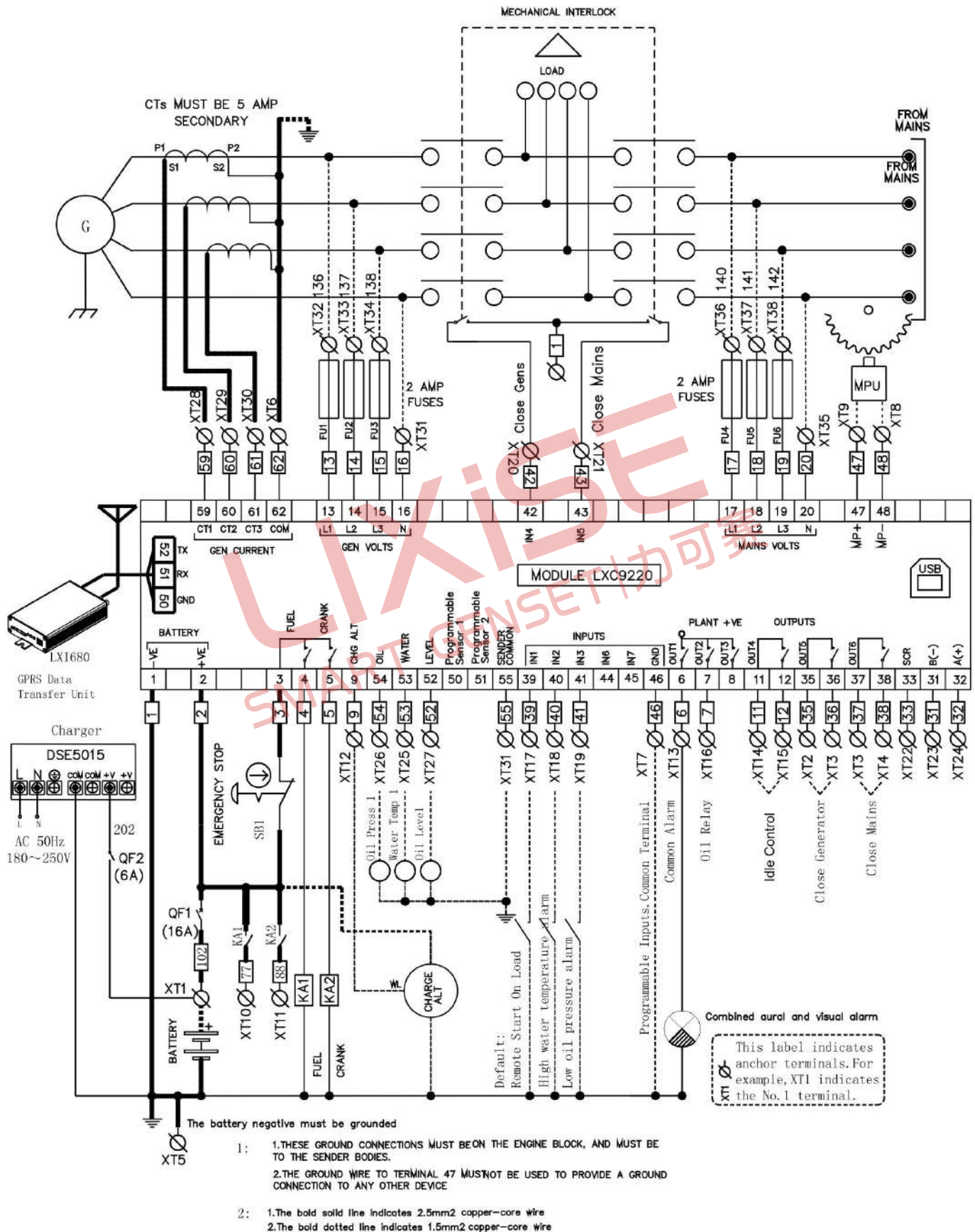

13. Installation

LXC92X0 Controller is panel built-in design; it is fixed by clips when installed. The controller's overall dimensions and cutout dimensions for panel, please refers to as following.

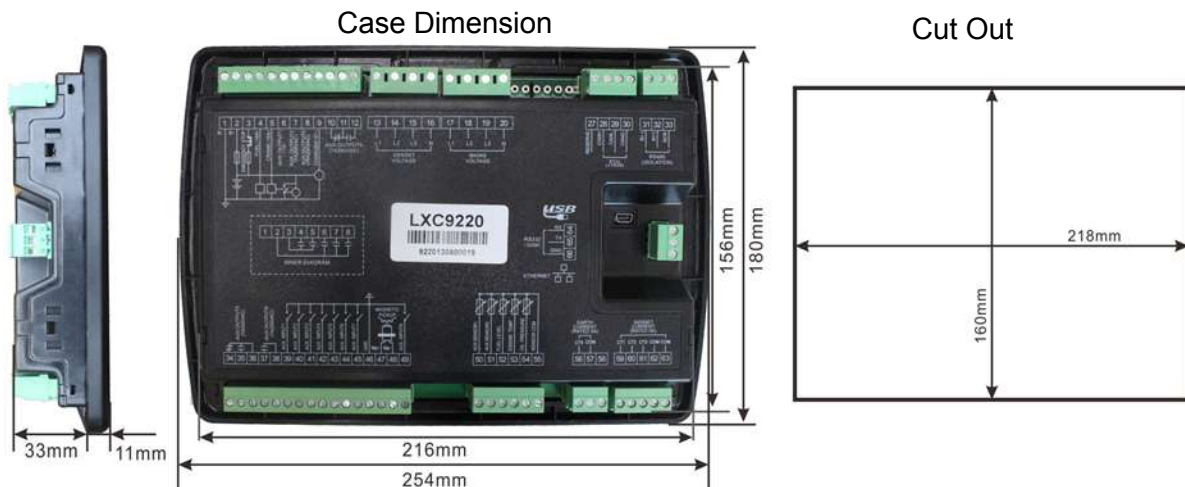

This section contains a number of very important considerations.

Controller installation instructions notes			
NO.	Item	Note,Warning, Caution	Description
1	Voltage Input	⚠️: 8~35VDC	Negative of battery must be connected with the shell of starter stable.
2	Connect controller to battery	⚠️: Wire $\geq 2.5\text{mm}^2$	The diameter of wire which from power supply to battery must be over 2.5mm^2 .
3	Battery Charger	⚠️: Charger must be connected directly to the battery.	Please firstly connect output wires of charger to battery's positive and negative directly, then, connect wires from battery's positive and negative to controller's positive and negative input ports in order to prevent charge disturbing the controller's normal working.
4	Speed Sensor Input	⚠️: 2 cores shielding line	Speed sensor is the magnetic equipment which be installed in starter and for detecting flywheel teeth. Its connection wires to controller should apply for 2 cores shielding line. The shielding layer should connect with No.18 terminal in controller while another side is hanging in air. The else two signal wires are connected with No.17 and No.18 terminals in controller. The output voltage of speed sensor should be within (1~24) VAC (effective value) during the full speed.
5	Output And Expand Relays	⚠️: Please add freewheel diode to both ends of expand relay's coils or, increase resistance-capacitance return circuit	All outputs of controller are relay contact output type. If need to expand the relays, please add freewheel diode to both ends of expand relay's coils (when coils of relay has DC current) or, increase resistance-capacitance return circuit (when coils of relay has AC current), in order to prevent disturbance to controller or others equipment.
6	AC Input	⚠️: ICOM port must be connected to negative pole of battery controller power. ⚡: When there is load current, transformer's secondary side prohibit from open circuit.	Current input of controller must be connected to outside current transformer. And the current transformer's secondary side current must be 5A. At the same time, the phases of current transformer and input voltage must correct. Otherwise, the current of collecting and active power maybe not correct.
7	Withstand Voltage Test	⚠️: When controller had been installed in control panel, if need the high voltage test, please disconnect controller's all terminal connections, in order to prevent high voltage into controller and damage it.	

14. Common faults and exclusion

Following in my controller process more common failure and troubleshooting, if there is a failure of the other can not be solved, please contact my company.

Faults	Possible Solutions
Controller no response with power	Check starting batteries; Check controller connection wirings; Check DC fuse.
Genset shutdown	Check the bottom of the main interface warning; Check the genset AC voltage; Check DC fuse.
Controller emergency stop	Check emergence stop button is correct or not; Check whether the starting battery positive be connected with the emergency stop input; Check whether the circuit is open.
Low oil pressure alarm after crank disconnect	Check the oil pressure sensor and its connections.
High water temp alarm after crank disconnect	Check the temperature sensor and its connections.
Shutdown Alarm in running	Check related switch and its connections according to the information on LCD; Check programmable inputs.
Crank not disconnect	Check fuel oil circuit and its connections; Check starting batteries; Check speed sensor and its connections; Refer to engine manual.
Starter no response	Check starter connections; Check starting batteries.
Genset running while ATS not transfer	Check ATS; Check the connections between ATS and controllers.
RS485 communication is abnormal	Check connections; Check setting of COM port is correct or not; Check RS485's connections of A and B is reverse connect or not; Check whether damage RS485transfer model; Check whether damage communication port of PC.

15. Product packaging

This product should be following sets:

- (1) 1 piece of controller model LXC92X0.
- (2) 4 pieces of fixed cards.
- (3) 1 piece of product certificate.
- (4) 1 piece of product manual.

LXC9220/LXC9210 Generator remote monitoring program



Dongguan Feirui Electronics Co.,LTD.

Tel:86-769-23162896

Fax:86-769-23166296

<http://www.lixise.com>

<http://www.lixise.net>

E-mail:sales@ smartgenset.com

Add: 18# Chashang industrial zone,
WenTang Road Dongguan City,
Guangdong, China