

DT4000 GS Cloud Monitoring Communication Module User Manual



Software Version

No.	Version	Date	Note
1	V1.0	2018-9-1	Original release.



Chongqing Mebay Technology Co.,Ltd

Add: No6-2,Building 4, Gangan Rd, Jiangbei District, Chongqing.

Tel: +86-23-6869 3061



Fax: +86-23-6765 8207

Web: <http://www.mebay.cn>

<http://www.cqmb.cn>

E_mail: sales@mebay.cn

Symbol Description

Symbol	Description
 Note	Remind operators to operate correctly, otherwise it may cause the equipment not to work correctly.
 Be care	It is indicated that potential hazards can damage equipment without proper precautions.
 Warning	It is indicated if appropriate preventive measures are not taken, potentially dangerous situations may result in death, serious personal injury or significant property losses.



Warning

1. The installation of this equipment must be carried out by professionals.
2. When installing and operating the controller, please read the entire instruction manual first.
3. Any maintenance and commissioning of the equipment must be familiar with all the equipmen
4. t, safety standards and precautions in advance, otherwise it may cause personal injury or damage to related equipment.
5. The engine must have an overspeed protection device independent of the controller system to avoid casualties or other damage caused by engine out of control.
6. After the installation of the controller is completed, please verify that all protection functions are valid.



Be Care

1. Please keep the good connection of the power supply of the controller. Do not share the connection lines of the positive and negative electrodes of the battery with the floating charger.
2. During the operation of the engine, do not disconnect the battery, otherwise it may cause damage to the controller.

Catalogue

1、 Summary.....	5
2、 Main Features.....	5
3、 Parameters.....	5
4、 Overall Dimension and Wiring Diagram.....	6
5、 Installation Instruction.....	7
6、 Panel and Display Instruction.....	8
7、 Operation.....	9
8、 Parameters list.....	11
9、 Fault finding.....	12

Notes:

1. All rights reserved. No part of this duplication may be reproduced in any material form (including photocopying or storing in any medium by electronic means or others) without the written permission of the copyright holder.
2. MEBAY Technology reserves the rights to change the contents of this document without prior notice.

Summary

DT4000 is the data acquisition and communication module of GSCLoud® generator set cloud control system developed by our company, which is 4G version. Its main function is to connect the generator set controller to the interconnection network, to realize the computer PC terminal and mobile phone APP remote real-time monitoring generator set, to realize the remote control unit, remote data monitoring, remote fault diagnosis, unit position real-time positioning, maintenance management and so on.

It has RS485 communication port, which can read and write the commonly controlled data. The internal integration of GPS module can realize the positioning of the unit. The communication module adopts European lock terminal, the connection is firm and the installation is convenient.

Main Features

- ◆ It can be connected to cloud server through 4G network, and a communication module can monitor a generator set.
- ◆ Using ARM kernel 32bit single chip microcomputer, processing speed, strong expansion ability.
- ◆ Wide range of working power supply DC ($8 \leq 36$) V.
- ◆ Support multiple network systems, LTE-TDD/LTE-FDD/WCDMA/TDSCDMA/GSM.
- ◆ It has good extended function, extensible environment detection, other equipment parameter detection and other modules.
- ◆ Data communication protocol using encryption algorithm.
- ◆ a compression algorithm is adopted to greatly reduce the flow consumption.
- ◆ the module is provided with the GPS positioning and the base station positioning function, and the real-time positioning of the unit can be realized.
- ◆ with two sets of programmable switch quantity input ports.
- ◆ When the generator set alarm, can immediately upload data to the server.
- ◆ the working state of the module is indicated by the LED indicating lamp, and the working state of the module is conveniently realized by the user in real time.
- ◆ The installation or screw fixation of the standard type 35mm guide rail is adopted.
- ◆ Modular structure design, ABS shell, light weight, compact structure, easy to install.

Parameters

Options	Parameters
Working voltage	DC8V----36V Continuous
Power consumption	Standby: 24V: MAX 1W
	Working: 24V: MAX 5W
USB Host	Type A USB port
USB Device	Type B USB port
RS485	Isolated
GPRS	SMA port
GPS	SMA port

Supported frequency band	LTE-TDD: B38/B39/B40/B41 LTE-FDD: B1/B3/B5/B8 WCDMA: B1/B8 TD-SCDMA: B34/B39 GSM:900/1800MHZ
SIM card	Nano SIM
Switch value input	Available if connecting with Battery -
Working condition	-25-65℃
Storage condition	-40-85℃
Overall dimension	106.5mm*74mm*31mm
Weight	0.15Kg

Overall Dimension and Wiring Diagram

◆ Overall Dimension:

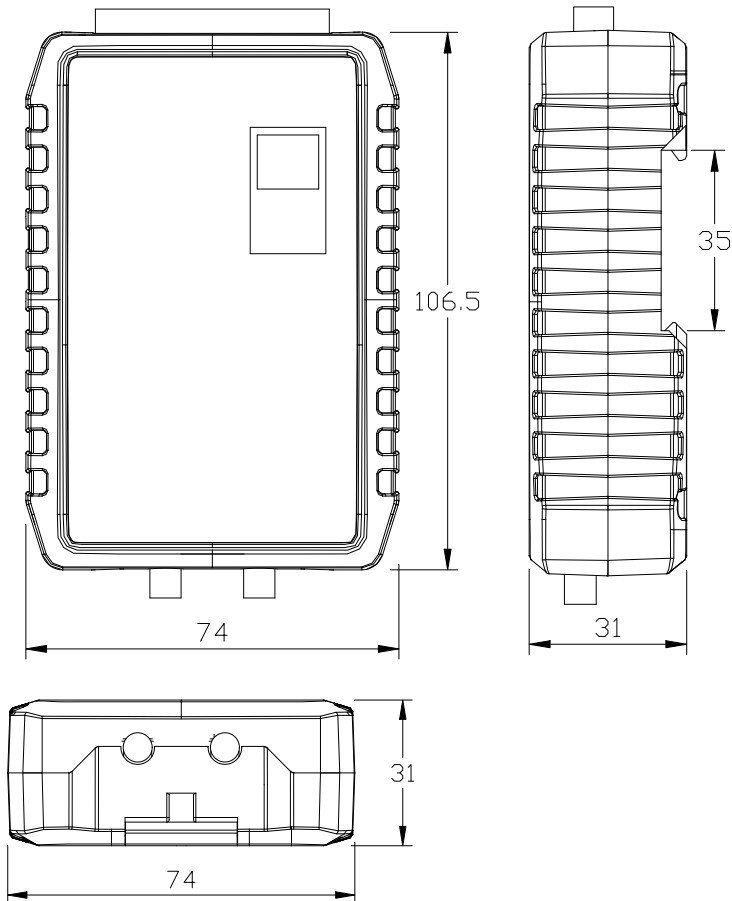

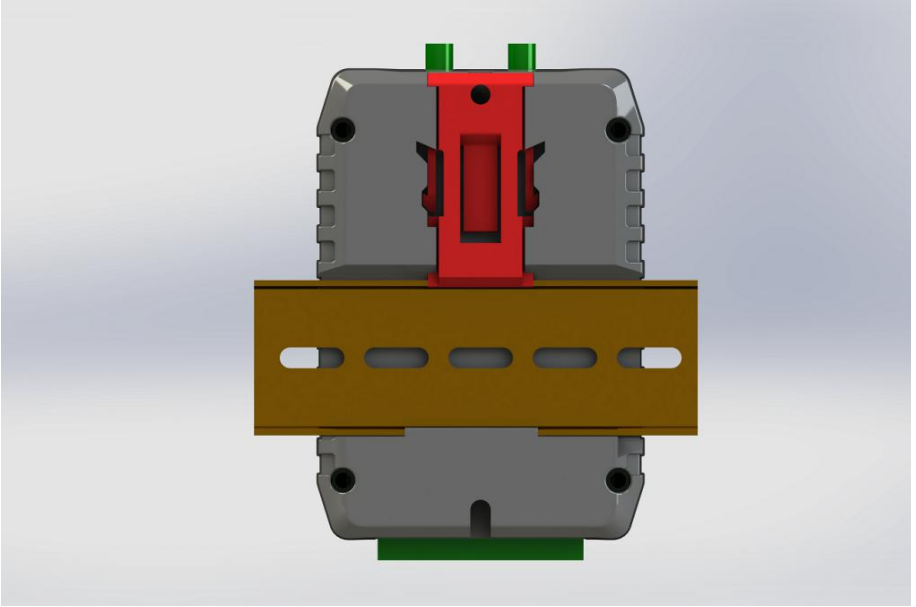
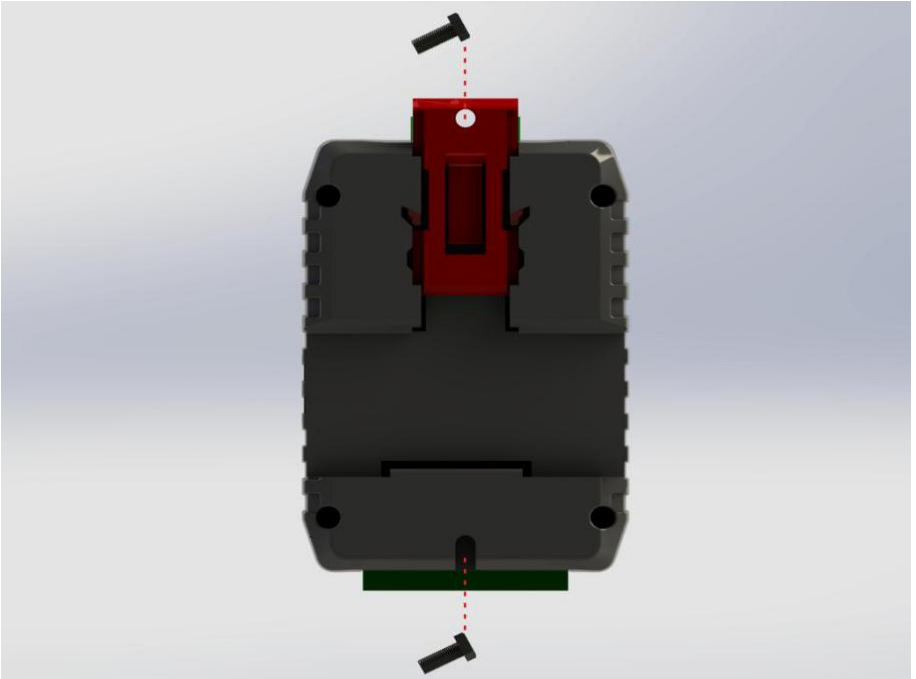
Installation instruction**◆ 35mm guideway installation:****◆ Screw (M4) installation:**

Panel and display Instruction



◆ Panel instruction

Indicator name	Main function
Data	DTU sends data in red for LED lights and green for LED lights when receiving data.
GPS	The GPS module successfully obtains the positioning information and lights it up.
Internet	Lights up after a successful connection to the Internet network.
Controller	When the DTU is successfully connected to the controller, the LED lights up.
Sever	When the DTU connects to the server successfully, the LED lights up.
Power	After the module is turned on, the LED lights up.

◆ Port description:

No.	Function	Description	Cable cross sectional area
1	Power +	DC8V to 36V continuous power supply	1.0mm ²
2	Power -		1.0mm ²
3	RS485-SCR	RS485 port	0.5mm ²
4	RS485-A		0.5mm ²
5	RS485-B		0.5mm ²
6	Aux. Input 1	Ground connected is active (B-).	0.5mm ²
7	Aux. Input 2	Ground connected is active (B-).	0.5mm ²
8	USB Device	Type B USB port	
9	SIM card	Nano SIM card	

Operation

◆ **Communication and port functions:**

RS485 port: Connect to the RS485 port of the generator controller through the

RS485 port:

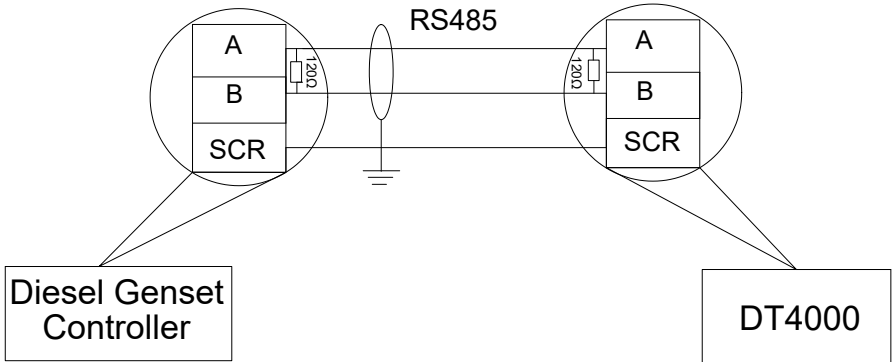

USB Device: USB port and PC USB port connection, can be parameter settings, module ID and registration password.

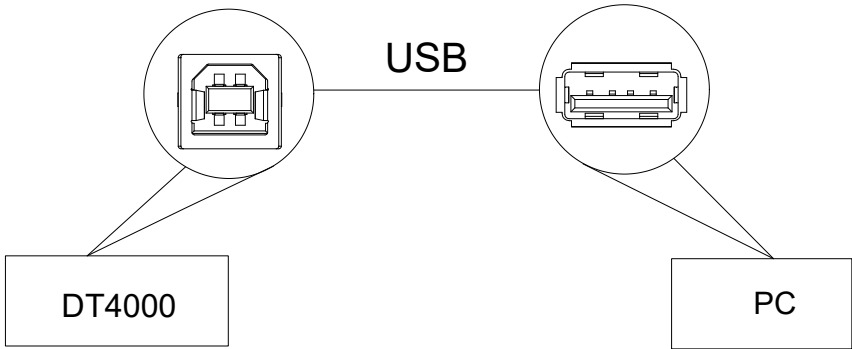

◆ **GPRS port :** Connect the GPRS antenna to the GPRS/ 4G port. Antenna parameters:50 Ω/ SMA female seat.

◆ **GPS port:** When using GPS positioning function, GPS antenna is connected to DTU module, antenna port: 50 Ω / SMA master, active antenna.

Note: GPS antenna needs to be placed outside the open, otherwise the position information is inaccurate or can not get the position information.

Note: The GPRS antenna and the GPS antenna cannot be reversed.

◆ **SIM card installation:**

The SIM card is inserted and the DTU will be connected to the server through the wireless mobile network. Standard Nano SIM card (25 mm to 15 mm in size).

◆ **System application diagram**

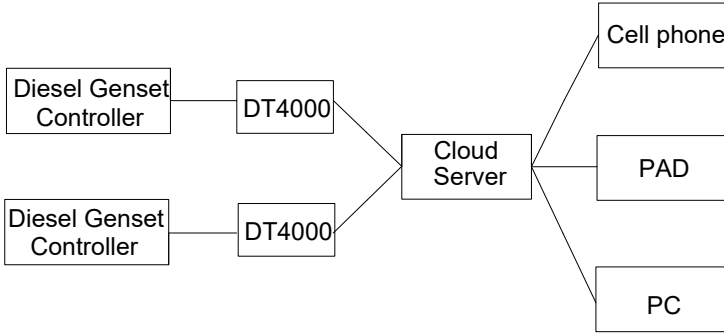

◆ **Typical Wiring Diagram**

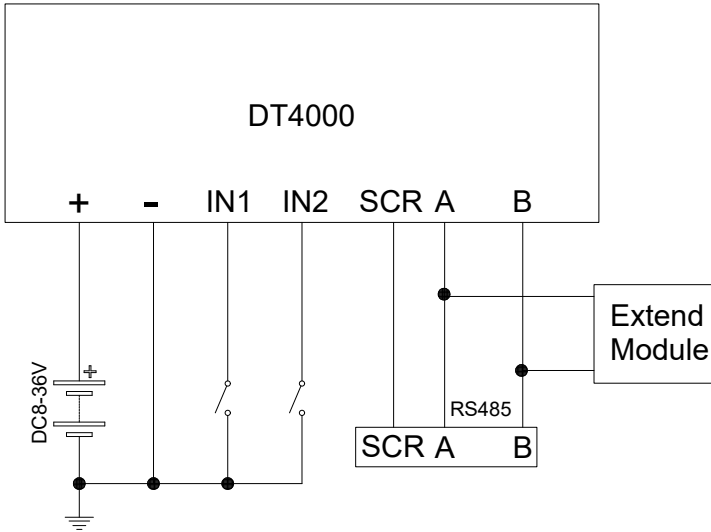

Parameter list.

1. GPS

No	Parameter	Range (default)	Notes
1	GPS functional enable	0-1(1)	0:manual input ; 1:GPS module acquisition position
2	Set Longitude	-180°-180°(0.00000)	Manual entry of communication module GPS location, altitude
3	Set latitude	-90°-90°(0.00000)	
4	above sea level	-9999.9-9999.9m(100.0m)	

2. GSM

No	Parameter	Range (default)	Notes
1	APN		40 characters
2	GPRS user name		40 characters
3	GPRS password		40 characters

3. Switch input function setting

No	Parameter	Range (default)	Notes
1	Aux. Input 1	0-9(0: disable)	0: disable 1: Remote Control Inhibited 2: Access Alarm Input 3: Fire Alarm Input 4: Louver status input 5-9: Reserved
2	Aux. Input 2	0-9(0: disable)	

4. Communication Settings

No	Parameter	Range (default)	Notes
1	485 baud rate	9600-38400(19200)	Baud rate of Communication between DTU and Controller.
2	Running data upload interval	10-170S(10)	The interval between uploading data to the server while the generator is running.
3	Standby data upload interval	90-170S(90)	The interval between uploading data to the server while the generator is standby.

5. Model selection of generator controller

No	Parameter	Range (default)	Notes
1	MEBAY	DC20D MKII DC4XD series	Select the model of the generator controller connected to the DTU. The DC4XD series can match the DC4xDR series, DC5xDR series, DC6xDR series and DC7xDR series generator controller produced by MEBAY.
2	Thompson Tech.	MEC20	Match the MEC20 controller from Thompson Technologies Inc.

6. Extended module setting

No	Parameter	Range (default)	Notes
1	Temperature and humidity module	0:Disable 1:Enable	Sets whether the temperature and humidity detection module is enabled.
2	Alarm value for excessive ambient temperature.	0-80(40) °C	When the ambient temperature is higher than this setting value, upload the alarm information with too high ambient temperature, and disable this alarm when set to the minimum value.
3	Alarm value of too low ambient temperature	-30-50(4) °C	When the ambient temperature is lower than this setting value, upload the alarm information of the environment temperature is too low, set to the maximum value to disable this alarm.
4	Temperature, humidity and CO module.	0:Disable 1:Enable	Sets whether the temperature, humidity and carbon monoxide concentration detection module is enabled.
5	CO concentration overhigh alarm value	0-2000ppm (250ppm)	When the carbon monoxide concentration is higher than this setting value, upload the carbon monoxide concentration alarm information, set to the maximum value to disable this alarm.

Fault Finding

Symptoms	Possible Solutions
Controller no response with power.	Check power voltage. Check controller connection wirings.
All LED lights are on.	Check SIM card is inserted or not. Check 4G antenna is connected or not.
GPS Not Gained Location	Check GPS parameters are enabled or not. Check GPS antenna is connected or not and placed outdoor or not. Check that the GPS antenna is placed outside the open room.
RS485 Communication Abnormal	Check connections Check settings of genset ID and baud rate are correct or not. Check that A and B of RS485 are reversed.
USB Port Communication Abnormal	Check connections Check whether the USB port of the computer is normal Check whether the driver is installed normally Check that the controller is properly energized